

Enhanced Gravity Concentrators- Prospects in Fine Coal Beneficiation

A. K. Majumder and J. P. Barnwal*

**Advanced Materials and Processes Research Institute (CSIR),
Formerly Regional Research Laboratory**

Bhopal 462026

Introduction

- ❖ In most of the coking coal washeries, around twenty percent of total feed coal has been found to be of below 500 μm size.
- ❖ The increased use of highly mechanized mining methodologies to enhance productivity has been the major cause of huge generation of coal fines.
- ❖ In the past, these coal fines were often considered to be too difficult to upgrade and were simply discarded into waste ponds without being processed.
- ❖ Froth flotation has been the established technique to process coal fines. However, the use of chemical reagents cause environmental hazards and makes the process cost intensive.

Enhance Gravity Concentrator

Enhanced gravity concentrators (EGCs) are gravity concentrators that employ centrifugal force to enhance the relative settling rate of particles by rotating the separating vessel itself.

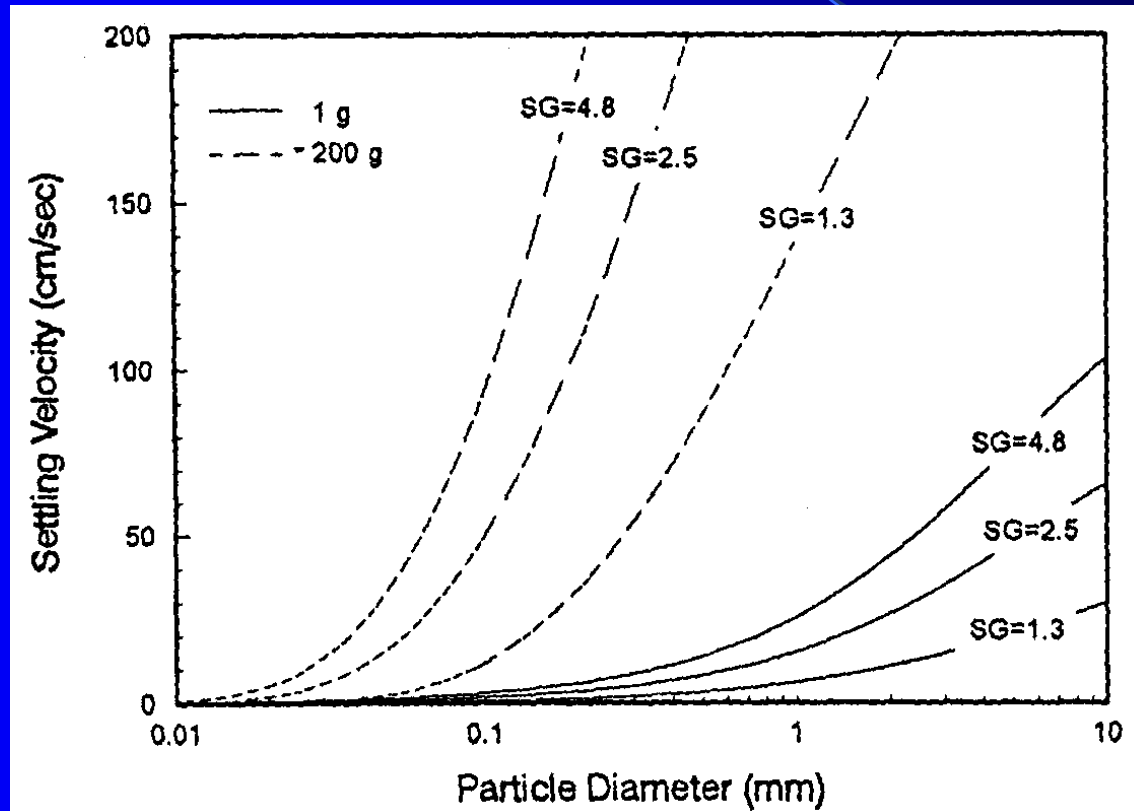

Effect of centrifugal force on particle settling velocities
(Luttrell, Honaker et al. 1995)

Comprehensive Review of Existing Centrifugal Separators

Technology	Principle	Centrifugal Force Maximum	Features	Application Ore Type
Knelson Concentrator	Fluidised Bed	60 g	Use of wash water minimum misplacement	Alluvial Gold
Falcon 'C' Series	Sluicing	300 g	High capacity, No wash water	Lead-Zinc, Copper, Gold, Iron, Tin, Coal.
Falcon 'SB' Series	Sluicing and Fluidised Bed	300 g	Better metallurgical performance	Alluvial-Gold
Kelsey Jig	Jigging	60 g	High Capacity	Chromite, Tantalum, Alluvial-Gold, Tin, Iron
Multi Gravity Separator	Shaking Table	22 g	Ability to treat very fine particles, Better metallurgical performance	Lead-Zinc, Copper, Gold, Iron, Tin, Coal.

Kelsey Jig

Kelsey jig

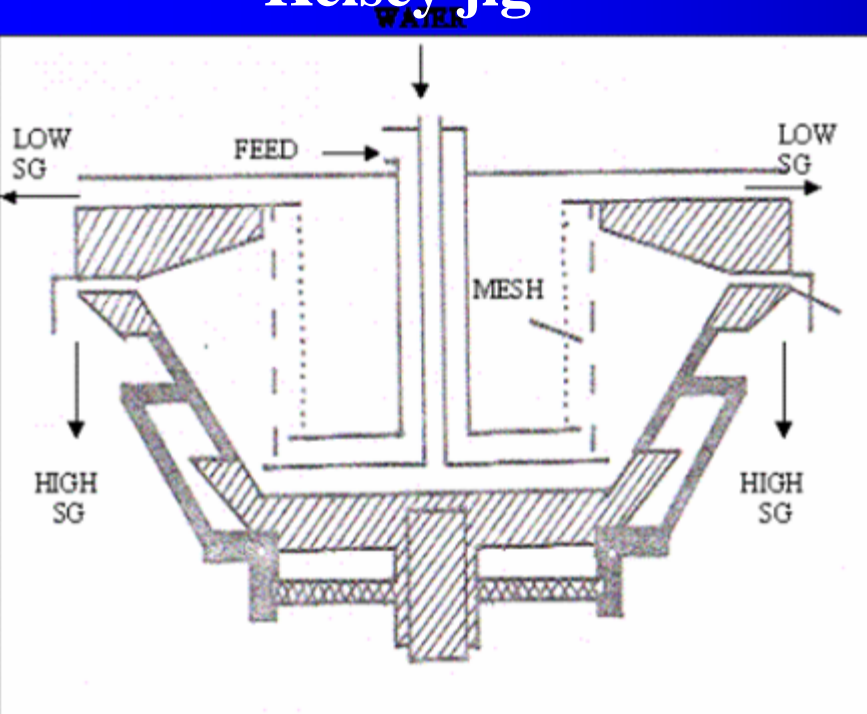

Experimental Data

Source	Feed Ash%	Clean Coal Ash%	Yield
Dugda	33.03	21.20	63.90
Moonidih	35.67	19.45	68.40
Jamadoba	23.82	18.40	71.40
Sudamdih	31.41	19.70	71.80
Nandan	21.56	16.20	74.30
Pathakhera	31.13	20.08	74.80
Mohan	34.76	19.70	71.60
Ghirwari Colliery	28.6	18.70	66.80
Ghirwari OCM	23.27	14.30	74.20
Ambana	28.74	16.40	73.20

Knelson Concentrator

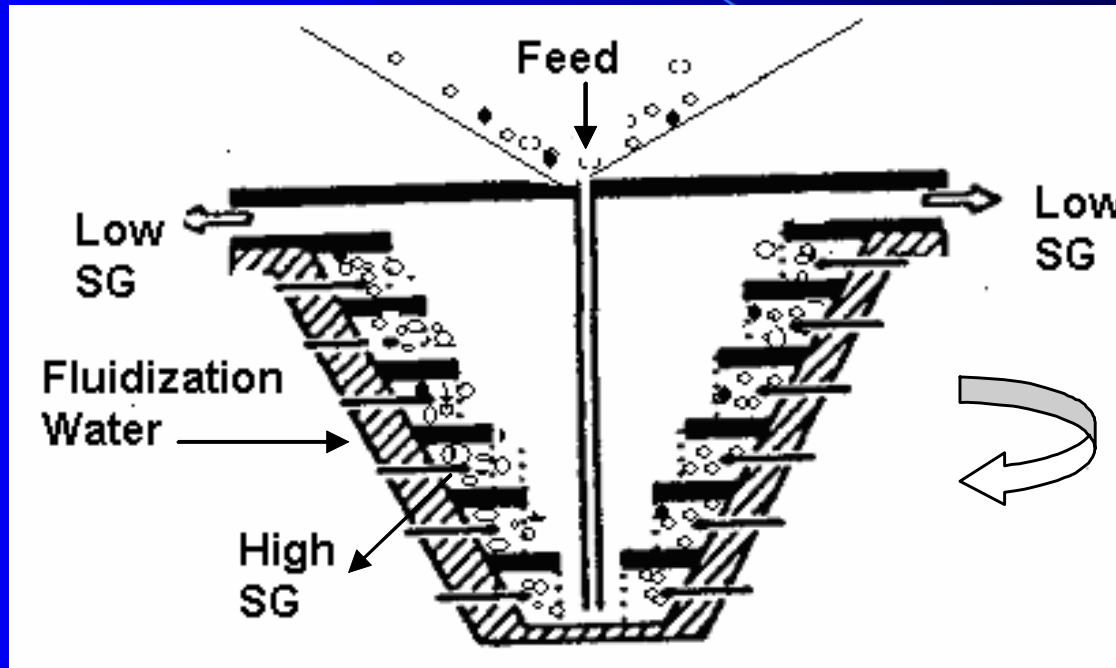

Falcon SB Concentrator

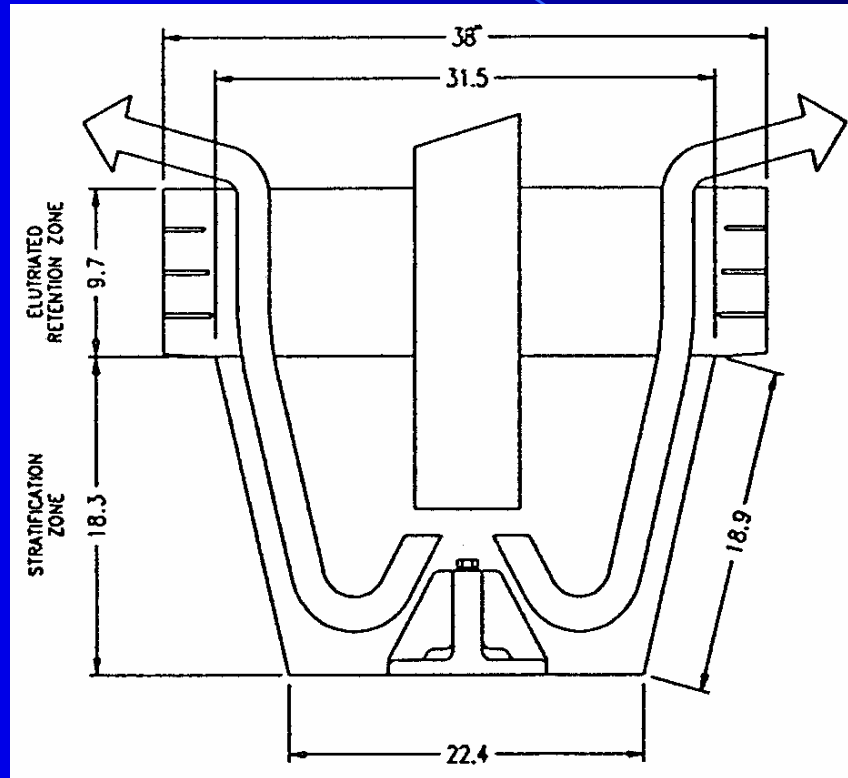

Mozley Multi Gravity Separator

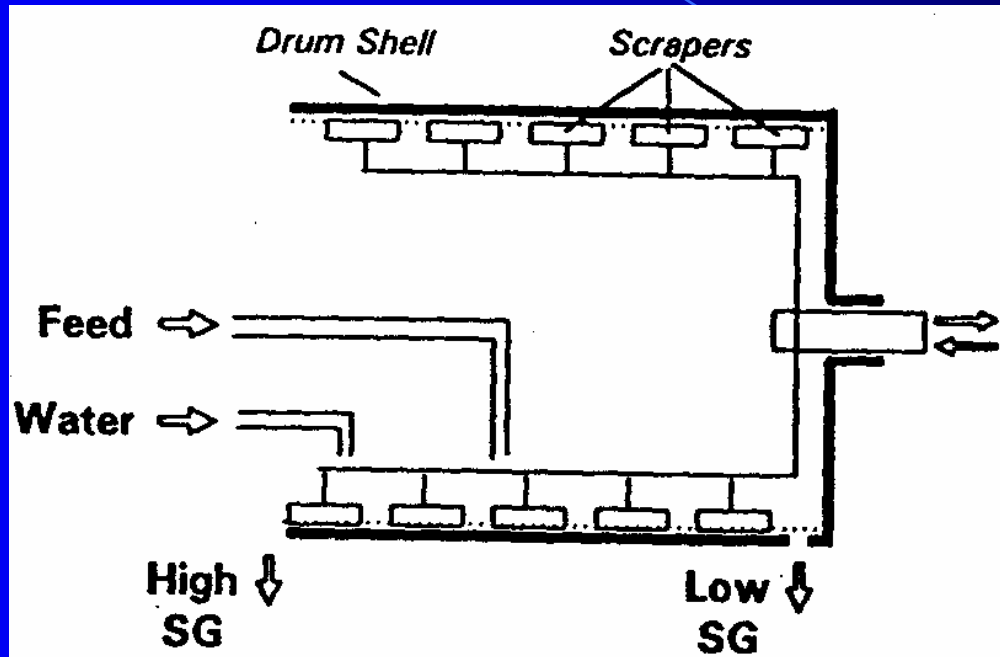

Experimental Data With Various Equipment

Equipment ↓	Source →	Patherdih		Bhojudih		Moonidih		Moonidih (Oxidized)	
	Feed Ash% →	36.61	24.71	23.08	30.5	CA	CY	CA	CY
Knelson Concentrator		16.57	65.00	14.13	70.2	17.98	80	19.52	65.15
Falcon SB Concentrator		16.37	69.20	14.61	65.68	17.23	78.6	18.62	63.4
Mozley Multi Gravity Separator		23.11	77.23	14.67	71	17.64	92.54	16.68	53.9
Water-only-cyclone		21.56	50.75	22.4	85.55	18.88	78.59	15.84	65.11

CA : Clean Coal %Ash CY : Clean Coal %Yield

Discussions

Feed Size Analyses of Various Coal Fines Studied

Particle Size (mm)	Patherdih		Bhojudih		Moonidih		Moonidih (Oxidized)	
	Wt%	Ash%	Wt%	Ash%	Wt%	Ash%	Wt%	Ash%
0.5-0.25	33.6	25.1	14.4	17	13.4	24.5	25.6	25.68
0.25-0.125	34.8	33.2	15.6	15.54	14.7	18.1	26.6	29.2
0.125-0.063	14.01	46.7	19.4	16.64	14.3	19.2	16.3	30.5
-0.063	17.59	57.31	50.6	32.83	57.6	24.98	31.5	35.51
	100	36.61	100	24.71	100	23.08	100	30.5

Summary

- 1. Enhanced gravity concentrators have tremendous possibilities to overcome the constraints associated with the established process of froth flotation in fine coal beneficiation.**
- 2. Amongst the enhanced gravity concentrators, Kelsey jig appears to be the most promising in fine coal beneficiation as the mode of particle separation inside this unit is continuous and the capacity of each unit is much higher than the other units.**
- 3. Water-only-cyclone will be very effective in processing coal fines where the ash contents of the ultra fines are less than the feed ash contents.**

Recommendation

- 1. Plant scale trials may be taken up with Kelsey jig treating coal fines. However, future research should be directed towards selection of more appropriate ragging material for beneficiation of coal fines.**
- 2. Combination of various EGC units may be studied on the overall efficiency of processing coal fines where the ash contents of the ultra fines are higher than the feed. Water-only-cyclone will be very effective in processing coal fines where the ash contents of the ultra fines are less than the feed ash contents.**

Acknowledgment

The authors would like to acknowledge the financial supports provided by the Council of Scientific & Industrial Research, India under the 'Network Program' on 'Quality Enhancement of Coal for its Effective Utilization' and the Ministry of Coal, Government of India to carry out this work.

Thank You

The image features the text "Thank You" in a bold, sans-serif font. Each letter is filled with a different color from a rainbow spectrum: 'T' is pink, 'h' is orange, 'a' is yellow, 'n' is green, 'k' is light blue, 'Y' is dark blue, and 'o' is purple. The text has a slight 3D effect with a white shadow cast to the left and slightly forward. The background is a gradient of blue, with a bright, curved light effect on the right side that fades into a darker blue.