

Carbon Sequestration leadership forum

www.cslforum.org



CARBON SEQUESTRATION LEADERSHIP FORUM

TECHNICAL GROUP

TASK FORCE ON

OFFSHORE CO₂-EOR

**Enabling Large-scale CCS using Offshore CO₂ Utilization and Storage
Infrastructure Developments**

EXECUTIVE SUMMARY

This report represents a review of the current status and potential for offshore CO₂-EOR and does not necessarily represent the views of individual contributors or their respective employers.

RECOMMENDATIONS TO DECISION MAKERS FOR OVERCOMING BARRIERS TO OFFSHORE CO₂-EOR

The key recommendations from this work is that governments and industry should work together to:

Increase the pace in deployment of CCS. This is a prerequisite for offshore CO₂-EOR and needs attention at the highest political level. Slow deployment may lead to missed windows of opportunity for CO₂-EOR, as the effect of CO₂-EOR will be reduced as the field gets more mature and, at some point, the benefit will be insufficient. There are few, if any, developed sources of CO₂ close to the offshore fields amenable to CO₂-EOR.

Start planning regional hubs and transportation infrastructures for CO₂. Building the networks will require significant up-front investments and the coordination of stakeholders, including industries, business sectors, and authorities that will have to work together. A one-on-one source to CO₂-EOR field linkage is likely to be more expensive per tonne CO₂ than a network, and to have low flexibility with respect to reduced need for fresh CO₂ and temporary stops in the CO₂ production. The activities will include CO₂ capture at regional clusters of power and industrial plants, transportation of the CO₂ to hubs and to the individual receiving fields, and injection management. Preliminary studies of the feasibility of such systems have already started in some regions, most notably the Gulf of Mexico and the North Sea. Such studies must be followed up.

Develop business models for offshore CO₂-EOR. Establishing offshore CO₂ networks will create many interdependencies and commercial risks concerning both economics and liabilities. Risk- and cost-sharing will be needed. The literature has a few examples that provide some thoughts, but these need to be matured. The business models must include fiscal incentives, e.g., in term of taxes or tax rebates.

Support RD&D to develop new technologies. CAPEX and OPEX for offshore CO₂-EOR are significant due to needed modifications and additional equipment on the platforms to separate CO₂ from the produced oil and gas and to make existing wells and pipes resistant to CO₂ corrosion. Development of new technologies can reduce the need for modifications and new equipment, for example, better mobility control or sub-surface separation systems. Use of existing pipelines may also be a way to keep investment costs down.

Continue to develop regulations specific to offshore CO₂-EOR. Many jurisdictions do not have regulations for offshore CO₂-EOR in place. Regulations should include monitoring the CO₂ in the underground, both during and particularly after closure and guidelines for when the field transfers into a CO₂ storage site.

BACKGROUND AND SUMMARY

At the Carbon Sequestration Leadership Forum (CSLF) Ministerial meeting in Riyadh, Saudi Arabia, in November 2014, the CSLF Technical Group formed a task force to identify technical barriers and R&D needs/opportunities for offshore enhanced oil recovery using carbon dioxide (CO₂-EOR), as a follow-up to earlier task forces on the technical barriers and R&D needs/opportunities related to sub-seabed storage of carbon dioxide and to technical challenges of conversion of CO₂-EOR projects to CO₂ storage projects.

The purpose of Carbon Capture and Storage (CCS) is to reduce emissions of greenhouse gases to the atmosphere as a climate change mitigation activity. CO₂-EOR as a technique can serve two purposes:

- Recover additional oil, thus supplying affordable energy and increasing revenues.
- Mitigate climate change by reducing CO₂ emissions to the atmosphere.

Which of these will be the main driver may differ between countries; however CO₂-EOR is widely recognised as a key component of the Carbon Capture Utilization and Storage (CCUS) concept.

This report provides an overview of the current technology status, technical barriers, and research and development (R&D) opportunities associated with offshore CO₂-EOR. Specifically, the report includes:

- **Differences between onshore and offshore CO₂-EOR.** These include more costly facilities offshore, issues related to CO₂ purity, regulatory issues including requirements for monitoring and maturity, well patterns and density, and already high recovery on many offshore fields.
- **Summary of global potential and economics of offshore CO₂-EOR.** The global potential for enhanced oil recovery from offshore field using CO₂-EOR is significant but assessments show variations as a result of different approaches.
- **Description of the world's first offshore CO₂-EOR project.** The Lula project offshore Brazil started injecting CO₂ in 2011. Project development history is described.
- **Brief description of approaches that may be used to enable offshore CO₂-EOR.** This includes late-life oil-field infrastructure, isolated satellite projects, reservoir modelling and focus on the residual oil zone (ROZ).
- **New and emerging technologies that can reduce the cost of offshore CO₂-EOR.** Smart and cost efficient topside solutions for processing CO₂-rich fluids, subsea technologies for separation and injection of CO₂, as well as solutions for improved mobility control are described.
- **Brief discussion of the supply chain needed for offshore CO₂-EOR.** This includes status on pipeline and ship transport, discussions on the need for CO₂ infrastructure, and some case studies.
- **Discussions on monitoring, verification and accounting (MVA) issues,** with emphasis on what is needed and the differences between CO₂-EOR and CO₂ storage.
- **Regulatory requirements and issues for offshore utilization and storage.** Examples of national regulations are given, differences between EOR and storage, as well as status on regulations regarding transition from EOR to storage.

Identified barriers to deployment of offshore CO₂-EOR

CO₂-EOR has been used onshore for many decades, particularly in North America but also to some extent in Europe (e.g. in Hungary and Croatia). In the United States (U.S.), the technique currently contributes 280,000 barrels of oil per day, just over 5% of the total U.S. oil production. Offshore, there is only one active project at the Petrobras operated field Lula offshore Brazil. This work has revealed few, if any, technical barriers to offshore CO₂-EOR. Elsewhere, the lack of offshore CO₂-EOR projects appears to be caused primarily by several barriers, some of which are shared by offshore CO₂ storage. The barriers fall in several categories:

- Related to technology:
 - a. High investment costs, CAPEX and additional operational costs, OPEX.
 - b. Loss of production while modifying facilities represents an additional up-front cost. Technology development can contribute to reduce the cost, although the value is also dependent on the required rate of return.
 - c. Reservoir characteristics are usually well known for mature oil fields but there will still be uncertainties around reservoir performance and the yield of additional oil.

- Related to implementation of CCS in general, where politicians and other decision makers can contribute:
 - a. Access to sufficient and timely supply of CO₂.
 - b. Lack of business models, also for offshore CO₂-EOR.
- Regulatory issues that regulators can mitigate:
 - a. There are uncertainties around regulations. It is not clear what requirements different jurisdictions will place on monitoring the CO₂ in the underground. While not being a barrier in itself, monitoring will require different considerations compared to offshore CO₂ storage and to onshore CO₂-EOR.
- Uncertainties around the revenues, namely the oil price and the cost of CO₂.
 - a. Volatile oil prices may prevent operators from implementing offshore CO₂-EOR unless new business models and/or changed tax regimes are implemented to de-risk investments.
 - b. Uncertainties around the price of CO₂ the oil field operator must pay to the CO₂ supplier, including the price of the CO₂ itself and the transportation costs. The first will often be subject to negotiations between seller and buyer and could be influenced by CO₂ prices in a trading scheme.

Contents

EXECUTIVE SUMMARY	2
ACKNOWLEDGEMENTS	9
1. INTRODUCTION	10
1.1. CARBON SEQUESTRATION LEADERSHIP FORUM (CSLF)	10
1.2. MOTIVATION FOR DOING OFFSHORE CO ₂ -EOR – MAIN DIFFERENCE TO CCS	10
1.3. TASK FORCE MANDATE AND OBJECTIVE OF REPORT	11
2. REVIEW OF OFFSHORE CO₂-EOR STORAGE	12
2.1 CO ₂ -EOR – HOW IT WORKS	12
2.1.1 <i>In the reservoir</i>	12
2.1.2 <i>CO₂ stream quality</i>	13
2.1.3 <i>Facilities for offshore CO₂-EOR</i>	14
2.2 DIFFERENCES ONSHORE VS. OFFSHORE CO ₂ -EOR.....	14
2.3 HISTORY AND STATUS OF OFFSHORE CO ₂ -EOR.....	15
2.4 GLOBAL TECHNICAL POTENTIAL FOR CO ₂ -EOR INCREMENTAL OIL AND CO ₂ STORAGE.....	16
2.5 REGIONAL UPDATES OF GLOBAL TECHNICAL POTENTIAL.....	17
2.5.1 <i>USA</i>	17
2.5.2 <i>North Sea</i>	17
2.5.3 <i>Other basins and revised global potential</i>	18
2.6 ECONOMICS OF OFFSHORE CO ₂ -EOR.....	20
3 INSIGHTS FROM LULA PROJECT – THE WORLD’S FIRST OFFSHORE CO₂- EOR PROJECT	23
3.1 BACKGROUND	23
3.2 RESERVOIR CHARACTERIZATION	25
3.3 ROBUST & FLEXIBLE DEVELOPMENT STRATEGY	26
3.4 MATERIALS	27
3.5 INTELLIGENT COMPLETION.....	27
3.6 PRODUCTION UNITS/TOPSIDE FACILITIES	28
3.7 LULA WAG PILOT	28
4. APPROACHES FOR ENABLING OFFSHORE CO₂-EOR	29
4.1 SMART SOLUTIONS FOR OFFSHORE CO ₂ -EOR OPERATIONS:	30
4.2 USING LATE-LIFE OILFIELD INFRASTRUCTURE	30
4.3 USING ISOLATED OILFIELD SATELLITE PROJECTS FOR DEDICATED CO ₂ -EOR PROJECTS.....	30
4.4 FOCUSING ON CO ₂ -EOR FOR RESIDUAL OIL ZONE RESERVOIRS OFFSHORE	31
4.5 CO ₂ -EOR RESERVOIR MODELLING, SIMULATION AND OPTIMIZATION ISSUES.....	31
4.6 APPLICATION OF NUMERICAL RESERVOIR SIMULATION IN CO ₂ -EOR	32
5. EMERGING TECHNICAL SOLUTIONS FOR OFFSHORE CO₂-EOR AND STORAGE	33
5.1 INTRODUCTION.....	33
5.2 TOPSIDE SOLUTIONS.....	34
5.2.1 <i>Goodyear study</i>	34
5.2.2 <i>Salim study</i>	35
5.2.3 <i>Energy Institute assessment</i>	36
5.2.4 <i>Studies on the Norwegian Continental Shelf (NCS)</i>	37
5.3 SUBSEA SOLUTIONS.....	40

5.3.1	<i>Subsea CO₂ processing</i>	40
5.4	NOVEL TECHNOLOGY ENABLING CO ₂ -EOR	42
5.4.1	<i>CO₂ separation</i>	42
5.4.2	<i>Oxy-fuel power generation</i>	44
5.5	NOVEL WELL TECHNOLOGY	46
5.5.1	<i>SWAG – Water Above Gas</i>	46
5.5.2	<i>WAG – alternating water gas injection</i>	48
5.6	MOBILITY CONTROL FOR CO ₂ -EOR	48
5.7	CONCLUSIONS	51
6.	CO₂ SUPPLY CHAIN ISSUES	51
6.1	CONSIDERATIONS WHEN CHOOSING TRANSPORT METHODS	51
6.2	STATUS AND CHALLENGES - PIPELINES.....	52
6.3	STATUS AND CHALLENGES – SHIP TRANSPORT.....	53
6.4	INITIATING NEW OFFSHORE TRANSPORT SYSTEMS	55
6.5	CASE STUDIES	55
6.5.1	<i>UK case studies</i>	55
6.5.2	<i>A Norwegian case – Gullfaks</i>	56
6.5.3	<i>A Vietnam case – Rang Dong Field</i>	57
6.6	CONCLUSIONS	58
7.	MONITORING, VERIFICATION AND ACCOUNTING TOOLS FOR OFFSHORE CO₂-EOR ...	58
7.1	ROLES AND EXPECTATIONS OF MONITORING, VERIFICATION AND ASSESSMENT FOR OFFSHORE CO ₂ -EOR	60
7.2	DIFFERENCES BETWEEN MVA FOR CO ₂ -EOR AND STORAGE OF CO ₂	62
7.3	DIFFERENCES BETWEEN MVA FOR ONSHORE CO ₂ -EOR AND OFFSHORE CO ₂ -EOR.....	63
7.4	TRANSITION CO ₂ -EOR TO STORAGE – IMPACT ON MONITORING	64
7.5	CONCLUSIONS	64
8.	REGULATORY REQUIREMENTS FOR OFFSHORE CO₂ UTILIZATION AND STORAGE	65
8.1	INTRODUCTION AND SCENE-SETTING	65
8.2	EXAMPLES OF SPECIFIC NATIONAL REGULATORY REQUIREMENTS.....	65
8.2.1	<i>UK</i>	65
8.2.2	<i>United States</i>	66
8.2.3	<i>Brazil</i>	66
8.2.4	<i>Gulf Cooperation Council Countries</i>	66
8.3	DIFFERENCES BETWEEN REGULATORY FRAMEWORKS FOR STORAGE AND EOR.....	67
8.4	REGULATIONS ON TRANSITION OF CO ₂ -EOR TO STORAGE: WHAT IS LACKING AND RECOMMENDATIONS HOW THIS MAY BE ACHIEVED	67
8.5	CONCLUSIONS	68
9.	SUMMARY OF BARRIERS FOR DEPLOYMENT OF OFFSHORE CO₂-EOR	68
10.	RECOMMENDATIONS FOR OVERCOMING BARRIERS FOR OFFSHORE CO₂-EOR	69
	REFERENCES	70

LIST OF FIGURES

Figure 2.1. Schematic showing the principles of miscible CO ₂ -EOR. From ARI & Meltzer Consulting (2010).....	13
Figure 2.2. Schematic diagram of offshore CO ₂ -EOR project facilities. From Goodyear et al. (2011).....	14
Figure 2.3. Basins for which the potential for incremental oil production and CO ₂ storage have been assessed, see Table 2.3.....	19

Figure 2.4. Possible cash flow in an offshore CO ₂ -EOR project. All numbers are fictitious but the presentation form is based on examples in Welkenhysen et al. (2015) and IEAGHG (2016).	21
Figure 2.5. Gulf of Mexico oil recovery potential with current as well as “next generation” technology (After Malone et al., 2014).	22
Figure 3.1- Location of the Lula Filed (red cross).	23
Figure 4.1- Illustration of the subsea satellite fields Alve, Stær and Svale developed by tie-back to the main Norne field (photo courtesy of Statoil ASA).	31
Figure 5.1. Areas that are affected on topsides facilities by introducing offshore CO ₂ -EOR operations according to Salim et al (2012).	35
Figure 5.2. Processing facilities on a new topsides EOR module according to Salim et al (2012).	36
Figure 5.3. A proposed schematic of two various options for topsides treatment of well stream from a CO ₂ flood from EI (2013).	37
Figure 5.4. Interfaces between existing infrastructure and new building blocks (Courtesy Aker Solutions).	38
Figure 5.5. Flow diagram showing modifications to and new equipment for the case C4. (Courtesy Aker Solutions).	39
Figure 5.6. Main functions of a typical processing concept for CO ₂ -EOR. (Courtesy Aker Solutions).	41
Figure 5.7. Supersonic nozzle with liquid separation. (From Netušil and Ditzl, 2012).	43
Figure 5.8. Basic system for supersonic CO ₂ separation. (From Imaev et al., 2014).	44
Figure 5.9. Illustration of subsea zero emission offshore power generation concept (Courtesy Aker Solutions).	46
Figure 5.10. XMT and downhole schematic, SWAG water injection through annulus. (Courtesy Aker Solutions).	47
Figure 6.1. Bow to stern loading from shuttle tanker (Courtesy Aker Solutions).	54
Figure 6.2 Shuttle tanker connecting directly to offloading buoy. (Courtesy Aker Solutions).	54
Figure 6.3. Conceptual vision of CO ₂ storage beneath the North Sea, linked to emission sources with capture. The insert shows fields in the UK Central North Sea which have been found particularly suitable technically and economically for CO ₂ -EOR. From SCCS (2015).	56
Figure 6.4. A network of sources and transportation means to supply Gullfaks with 5.5 MT CO ₂ /year. From Elsam (2003).	57
Figure 6.5. Location of the Rang Dong Field relative to the CO ₂ sources. From (Kawahara, 2016).	58

LIST OF TABLES

Table 2.1. US Gulf of Mexico technical oil recovery potential and associated CO ₂ storage potential, current and “next generation” technologies.	17
Table 2.2. Potential incremental oil production and CO ₂ stored from applying CO ₂ -EOR in the North Sea	18
Table 2.3. Potential incremental oil production and CO ₂ permanently stored in the basins shown in Figure 2.3.	19
Table 2.4. Some key input parameters to CO ₂ -EOR profitability studies and their relevant scales.	20
Table 2.5. US Gulf of Mexico economic oil recovery and associated CO ₂ storage potential, current and “next generation” technologies.	22
Table 4.1. Comparison of oil recovery factor using various injection techniques in an off-shore reservoir.	33
Table 7.1. Examples of MVA studies and projects for storage settings other than offshore EOR.	59
Table 7.2. General background on MVA (not specific to Offshore CO ₂ EOR settings).	59

Table 7.3. Resources on offshore monitoring.....59
Table 7.4. Resources on CO₂ EOR monitoring (with a focus on onshore settings).....60
Table 7.5. Comparing risks for CO₂-EOR and storage of CO₂
(Adapted from Hill et al., 2013).....62
Table 8.1. Overview of regulatory status of selected countries/regions (after CCP, 2016).....67

ACKNOWLEDGEMENTS

This report was prepared for the CSLF Technical Group by the Task Force on Offshore CO₂-EOR. The Task Force chair, Lars Ingolf Eide (Norway) thanks the following participants for their contributions and efforts:

Susan Hovorka, (University of Texas at Austin, U.S.)
Melissa Batum (U.S. Department of the Interior, Bureau of Ocean Energy Management)
Tim Dixon (IEA Greenhouse Gas R&D Programme)
David Ryan (Natural Resources Canada | Ressources naturelles Canada)
Raphael Augusto Mello Vieira (Petrobras, Brazil)
Heron Gachuz Muro (Pemex Exploration and Production, Mexico)
Philip Ringrose (Statoil, Norway)
Sveinung Hagen (Statoil, Norway)
Bamshad Nazarian (Statoil, Norway)
Arne Graue (University of Bergen, Norway)
Pål Helge Nøkleby (Aker Solutions, Norway)
Geir Inge Olsen (Aker Solutions, Norway)
Zabia Elamin (Aker Solutions, Norway)

Each individual and their respective country have provided the necessary resources to enable the development of this work.

The task force members would like to thank John Huston of Leonardo Technologies, Inc. (United States), reviewing and suggest valuable editorial input to the report.

This report represents a review of the current status and potential for offshore CO₂-EOR and does not necessarily represent the views of individual contributors or their respective employers.

1. Introduction

1.1. Carbon Sequestration Leadership Forum (CSLF)

The Carbon Sequestration Leadership Forum (CSLF; <https://www.cslforum.org>) is a Ministerial-level international climate change initiative that is focused on the development of improved cost-effective technologies for the separation and capture of CO₂ for its transport and long-term safe storage. Its mission is to facilitate the development and deployment of such technologies via collaborative efforts that address key technical, economic, and environmental obstacles.

The CSLF comprises a Policy Group (PG) and a Technical Group (TG). The PG governs the overall framework and policies of the CSLF, and focuses mainly on policy, legal, regulatory, financial, economic, and capacity building issues. The TG reports to the PG and focuses on technical issues related to Carbon Capture, Utilization and Storage (CCUS) and on CCUS projects in member countries.

At the CSLF Ministerial meeting in Riyadh, Saudi Arabia, in November 2014, the CSLF Technical Group formally moved forward with a task force to identify technical barriers and R&D needs/opportunities for offshore enhanced oil recovery (EOR) using carbon dioxide (CO₂-EOR), as a follow-up to earlier task forces on the technical barriers and R&D needs/opportunities related to sub-seabed storage of carbon dioxide (CSLF, 2015) and to technical challenges of conversion of CO₂-EOR projects to CO₂ storage projects (CSLF, 2013).

1.2 Motivation for doing offshore CO₂-EOR – main difference to CCS

The purpose of injecting of CO₂ into an oil reservoir is to enhance oil recovery (hereinafter called CO₂-EOR). The technology has been in operation onshore for over 40 years (Enick et al., 2012), particularly in North America. In the United States, the technique currently contributes 280,000 barrels of oil per day, just over 5% of the total U.S. oil production. CO₂ injection for EOR can be an effective way to recover additional oil after water-floods or pressure depletion, while at the same time store large quantities of CO₂ underground (Malik and Islan, 2000).

The purpose of Carbon Capture and Storage (CCS) is to reduce emissions of greenhouse gases to the atmosphere as a climate change mitigation activity. CCS with CO₂ injection into sedimentary rocks is considered to be an important, large-scale solution for reducing the emission of anthropogenic CO₂ (IPPC, 2005). For example, the storage capacity in saline aquifers and mature hydrocarbon reservoirs located in the North Sea formations will likely be sufficient for all EU point sources for the fossil era. Offshore injection and storage of CO₂ into geological formations for the purpose of preventing it from reaching the atmosphere (Carbon Capture and Storage, hereinafter called CCS) has taken place in Norway since 1996 (IEA, 2016a).

CO₂-EOR as a technique can thus serve two purposes:

- Recover additional oil, thus supplying affordable energy and increasing revenues.
- Mitigating climate change by reducing CO₂ emissions to the atmosphere.

Which of these will be the main driver may differ between countries.

Other differences between CCS and CO₂-EOR are (CSLF, 2013; CCP¹, 2016):

- CO₂ quality and purity: CCS projects are based on anthropogenic CO₂ whereas the majority of CO₂-EOR projects have used natural occurring CO₂ until the present.
- Regulatory issues: CO₂-EOR and CCS projects are regulated differently (see Section 7.3).

Benefits and technical aspects of CO₂-EOR are discussed in earlier CSLF reports (CSLF 2013, 2015). CO₂-EOR projects are primarily implemented to increase tertiary oil production and any long-term storage of CO₂ will be a potential ancillary benefit. When projects are designed as CCS projects from the start, there is typically a site evaluation process to review the storage formation according to best practice criteria for CCS.

Offshore CO₂-EOR is seen as a way to catalyse offshore storage opportunities and start building the necessary infrastructure networks. It will also help to address both global energy needs and the current climate-change challenges. Huge amounts of energy are needed for future generations to sustain or improve standard of living, thus existing energy supply needs to be optimized in an environmental friendly way and new energy resources must be found. IEA² estimates that 45% of the primary energy supply, even in a two-degree scenario (2DS³), will be from fossil fuels by 2050 (IEA, 2016). To keep CO₂ emissions from the fossil sources sufficiently low to meet the 2DS target, IEA argues that CCS will have to play a significant role. Two aspects of these strategies utilise CO₂ as a commodity: CO₂ for EOR as enabler of CCUS (Carbon Capture, Utilization and Storage), and CO₂ injection in hydrates; the latter being a potential win-win situation for CO₂ storage with simultaneous natural gas production (Graue et al. 2006, Birkedal, et al., 2010, Graue et al., 2008, Kvamme et al., 2007). However, CO₂ injection in hydrates is an immature technology and a major challenge is up-scaling laboratory results to the field scale.

A plausible future scenario is that the need for reduced CO₂ emissions may be reached by CCS and CCUS, with CO₂-EOR and saline aquifer storage as the main contributors. An international approach will ensure that the effort has interdisciplinary expertise from different countries, such as the knowledge transfer opportunities from CCUS experience in the USA combined with sharing experience from recent large scale offshore experience from Brazil. Collaboration between countries on different continents contributes to effectively disseminate results globally.

1.3 Task Force Mandate and Objective of report

The main barriers reported widely for offshore CO₂-EOR projects are the investment required for the modification of platforms and installations, the lost revenue during modification, the lack of CO₂, and the lack of a transportation infrastructure. Recent advances in subsea separation and processing could extend the current level of utilization of sea bottom equipment to also include the handling of CO₂ streams. It has been recommended that RD&D activities explore opportunities to leverage existing infrastructure and field test advances in subsea separation and processing equipment (CSLF, 2015).

The CSLF Offshore Storage Task Force report (CSLF, 2015) covered some of the above topics related to offshore CO₂-EOR, but the CSLF TG found that a more in-depth review may be warranted. Thus, the Offshore CO₂-EOR Task Force was mandated to review and summarize recent findings, including

¹ CCP4 = CO₂ Capture Project (CCP) is a partnership of major energy companies working together to advance CCS technologies

² IEA: International Energy Agency

³ An emissions trajectory that will give a 50 % chance of limiting the rise in the average global temperature from anthropogenic GHG emissions to 2°C

the additional monitoring techniques that may be applied offshore. It may position CSLF to encourage members to implement the technology.

Norway volunteered to serve as chair of the task force whose mandate is to develop a report that will:

- Summarize current assessment or understanding (using available analyses) on the status of global offshore CO₂-EOR storage potential;
- Identify existing projects and characterization activities worldwide on offshore CO₂-EOR storage and progress to date;
- Identify the technical barriers/challenges to offshore CO₂-EOR storage (e.g., availability of CO₂, HSE⁴, monitoring, use of existing offshore facilities; transport challenges and R&D opportunities);
- Summarize the main differences between offshore and onshore CO₂-EOR;
- Discuss issues that are different between offshore CO₂-EOR and pure offshore CO₂ storage;
- Point to technical solutions that will benefit both pure offshore CO₂ storage and offshore CO₂-EOR;
- Identify potential opportunities for global collaboration; and
- Include conclusions and recommendations for consideration by CSLF and its member countries.

2. REVIEW OF OFFSHORE CO₂-EOR STORAGE

2.1 CO₂-EOR – how it works

2.1.1 In the reservoir

Enhanced oil recovery (EOR) is a term used for a set of techniques that increase the amount of crude oil that can be extracted from an oil field. Oil recovery is also classified as using primary pressure depletion, secondary (mainly waterflooding) and tertiary recovery mechanisms (including CO₂ or gas injection). Waterflooding is the dominant oil recovery mechanism globally, but tertiary mechanisms are being increasingly applied. In the United States the injected gas is primarily CO₂, whereas in the North Sea natural gas injection dominates. In CO₂ injection projects, the injected CO₂ may contain H₂S in which case the process is then termed sour gas injection.

In the CO₂-EOR process, CO₂ is injected into an oil reservoir under high pressure. Oil displacement by CO₂ injection relies on the phase behaviour and properties of the mixture of CO₂ and oil, which are strongly dependent on reservoir temperature, pressure and oil composition. There are two main types of CO₂-EOR processes (ARI and Melzer, 2010):

Miscible CO₂-EOR is a multiple contact process involving interactions between the injected CO₂ and the reservoir's oil. During this multiple contact process, CO₂ vaporizes the lighter oil fractions into the injected CO₂ phase and CO₂ condenses into the reservoir's oil phase. This leads to two reservoir fluids that become miscible (mixing in all parts), with favourable properties of low viscosity, enhanced mobility, and low interfacial tension. The primary objective of miscible CO₂-EOR is to remobilize and dramatically reduce the residual oil saturation in the reservoir's pore space after water flooding. Figure 2.1 provides a one-dimensional schematic showing the dynamics of the miscible CO₂-EOR process. Miscible CO₂-EOR is by far the most dominant form of CO₂-EOR deployed. In some cases, the miscible CO₂-EOR process may not be fully miscible with portions of the displacement being

⁴ HSE = Health, Safety and Environment

immiscible (e.g., due to pressure drops).

Immiscible CO₂-EOR occurs when insufficient reservoir pressure is available or the reservoir's oil composition is less favourable (heavier). The main mechanisms involved in immiscible CO₂ flooding are: (1) oil phase swelling, as the oil becomes saturated with CO₂; (2) viscosity reduction of the swollen oil and CO₂ mixture; (3) extraction of lighter hydrocarbon into the CO₂ phase; and, (4) fluid displacement. This combination of mechanisms enables a portion of the reservoir's remaining oil to still be mobilized and produced, and is commercial in many instances.

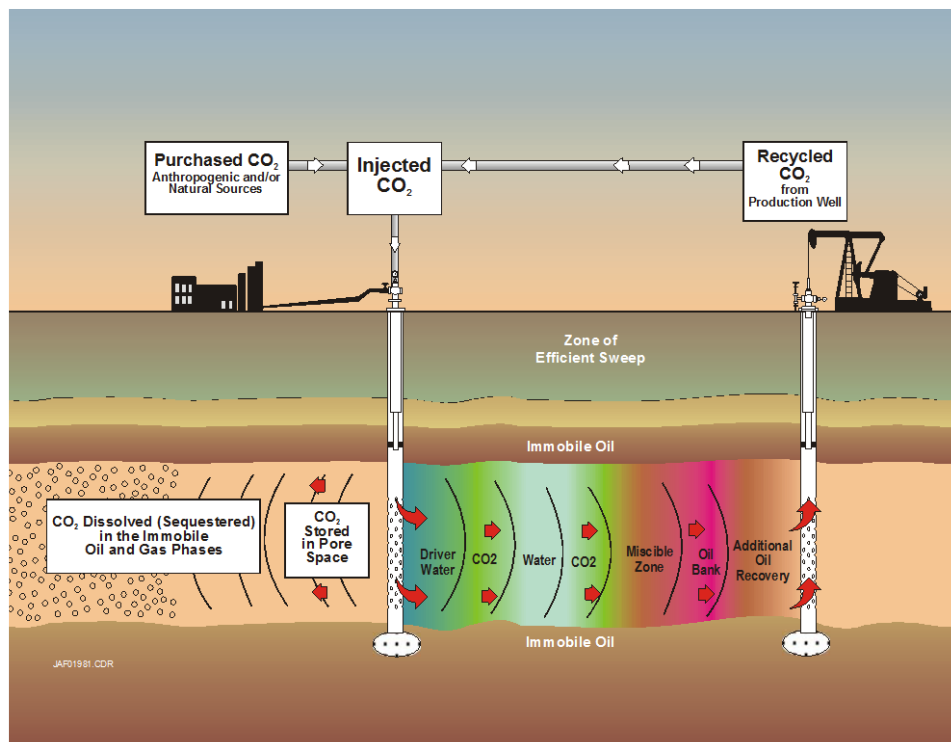

Figure 2.1. Schematic showing the principles of miscible CO₂-EOR. From IEAGHG (2009) reprinted with permission from IEAGHG

2.1.2 CO₂ stream quality

The exact conditions for achieving miscibility are reservoir-specific because flooding a reservoir with CO₂ for CO₂-EOR must meet a specific combination of conditions defined by reservoir temperature, reservoir pressure, injected gas composition, and oil chemical composition. Impurities in the injected CO₂ stream in a CO₂-EOR project could hinder the ability of the injected fluid to meet the criteria for achieving miscibility (Godec, 2011).

The specifications for the CO₂ stream quality will also be dictated by requirements for the safe, reliable, and cost effective transport of the CO₂. Impurities in the CO₂ stream can impact the transport capacity of the pipeline, the potential for micro-fractures in the pipeline, and other safety and operational considerations. Meeting such pipeline standards has permitted the CO₂ pipeline industry to safely transport CO₂ with no demonstrated examples of substantial leakage, rupture, or incident. In fact, CO₂ pipelines in the U.S. have a safety record which is better than that of comparable natural gas pipelines. Thus, meeting the specifications for CO₂-EOR should also allow for the safe, reliable, and economical transport of CO₂ (Godec, 2011). However, a consensus on the CO₂ stream composition for pipeline transport appears to be lacking. The new ISO standard on Transportation of CO₂ (ISO, 2016) gives no recommendation due to lack of published data by stating that “*The most up to date*

research should be consulted during pipeline design". However, some example CO₂ stream compositions are given by De Visser et al. (2008), indicating that typical compositions are around 95-96% CO₂ with hydrocarbon gas fractions around 2-5%.

2.1.3 Facilities for offshore CO₂-EOR

In a CO₂-EOR operation floodable hydrocarbons (mainly oil), CO₂ and brine are produced to surface at production well(s). The elements involved in a typical offshore CO₂-EOR are indicated in Figure 2.2 (Goodyear et al., 2011). Flue gas from onshore sources (anthropogenic or natural) is compressed for transport. In the case of Figure 2.2 transport is by pipeline but it could also be transported by ship. With a ship solution the onshore compressor station would be replaced by a conditioning unit (which may also include a compressor). The CO₂ arrives at a central processing facility (CPF), where it may be boosted to obtain injection pressure. For safety reasons the CPF is located close to the injection point, here illustrated as a separate wellhead platform (WHP). After sweeping the oil reservoir, back produced CO₂ along with oil, brine, and hydrocarbon gas are routed back to the CPF, oil is separated for export, brine treated and disposed and the recovered CO₂ mixed with imported CO₂, compressed and re-injected. The amount of back produced CO₂ increases with time and need for imported CO₂ decreases over time.

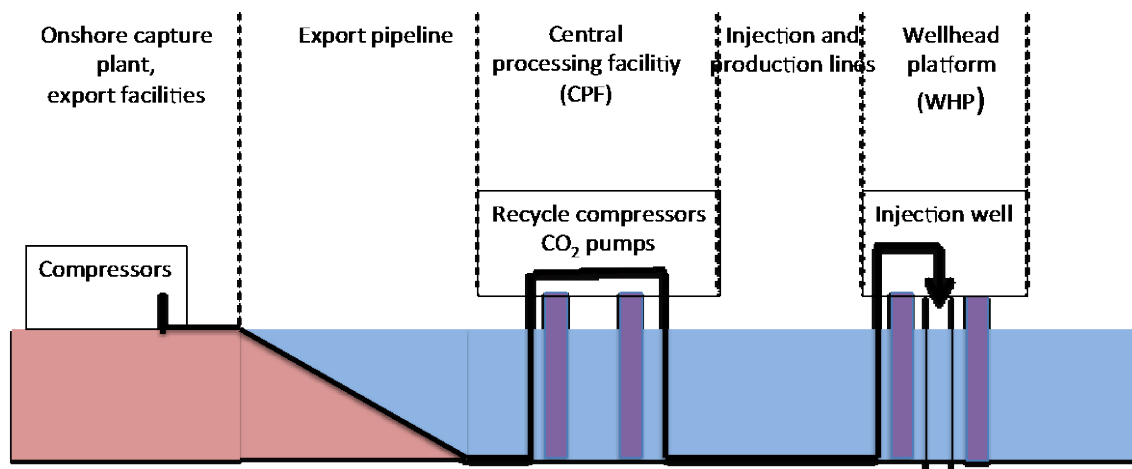

Figure 2.2. Schematic diagram of offshore CO₂-EOR project facilities. Based on an illustration by Goodyear et al. (2011),

2.2 Differences onshore vs. offshore CO₂-EOR

The production mechanisms are principally the same in onshore and offshore CO₂-EOR settings, and future CO₂-EOR operations offshore will mimic and utilise technologies known from the more matured on-shore business, in order to increase recoverable resources from the reservoir. However, offshore implementation poses additional challenges that include:

- Onshore CO₂-EOR has been conducted for several decades and is a mature technology, whereas large-scale offshore CO₂-EOR has been on-going for about five years only (Lula project, Chapter 3 below).
- Offshore operations are conducted from a platform, or via subsea facilities tied back to a platform, creating both technical and financial hurdles.
- Well patterns differ significantly between onshore and offshore projects. Offshore wells tend to be horizontal and onshore wells vertical. This usually implies a higher well density onshore than offshore and may require special considerations offshore, as discussed by, amongst others, Goodyear et al. (2011) and Stuart and Haszeldine (2014)

- The investments (CAPEX) required for the modification of existing platforms, wells, and other installations will be higher offshore than onshore, and the lost revenue during the modification process can be a very significant factor. However, new fields can be designed for the requirements of CO₂-EOR cost effectively.
- Operational costs (OPEX) and maintenance are more costly offshore than onshore.
- Offshore fields have often achieved higher recovery (prior to potential start of CO₂-EOR) due to the higher investment in well technology (e.g., horizontal wells) and reservoir management (e.g., use for time-lapse seismic). There may thus be less to gain from CO₂-EOR as compared with onshore fields where only waterflood from vertical wells has been applied prior to CO₂-EOR.
- In a CO₂-EOR operation offshore, CO₂ will be delivered by ship or offshore pipeline, both creating additional costs compared to the onshore solution. The CO₂ may be injected directly into the wells, or temporarily stored (in floating storage vessels), enabling a choice of injection strategies.
- There are differences in the reservoir management capability, foremost due to larger well spacing offshore and the constraints of operating from a platform.

Despite these additional challenges for offshore CO₂-EOR, there may also be some upsides for the offshore setting, such as:

- Offshore leases will generally be owned by single licensing authorities, making offshore CO₂-EOR projects less complex to plan and execute.
- Larger field sizes offshore may correspond to significant potential for higher additional production from CO₂-EOR.

2.3 History and status of offshore CO₂-EOR

Significant experience exists in onshore CO₂ injection for EOR. There has been extensive offshore exploration and production of hydrocarbons since the 1960s in many basins throughout the world, however, the use of CO₂-EOR offshore is very limited so far. CSLF (2015) gives an overview of the history and status of offshore CO₂-EOR, which is summarized below. The cases for which CO₂ has been considered to enhance offshore hydrocarbon production include:

1. In Malaysia (Sarawak), the enormous Petronas K5 Project and other prospects in the southern South China Sea propose to produce natural gas from fields with up to 70% carbon dioxide. The concept being pursued is to use the CO₂ to boost production in depleting nearby offshore oilfields.
2. In Vietnam, a small-scale pilot test was conducted at the Rang Dong Oilfield, located 135 km off the coast of Vung Tau, in 2011. In the project, 111 tonnes (t) of CO₂ were injected through an existing production well, followed by a four-day oil recovery test with the same well two days later. The test was successful and an extended inter-well pilot test is under planning as a next step (Ueada, 2013).
3. Offshore Norway, several technical feasibility studies for CO₂-EOR have been conducted, for example at the giant Gullfaks field (sandstone; Augustsson, 2005), the Heidrun and Draugen fields (sandstone; Carbon Capture Journal, 2007) and the Ekofisk field (chalk; Hustad and Austell, 2004). These studies demonstrated the technical feasibility of large-scale CO₂ injection for EOR offshore, but have not progressed past the feasibility stage. More recently, Holt et al. (2009), Pershad et al. (2012, 2014), NPD⁵ (2014), Energy Research Partnership (2015), SCCS⁶ (2015), Welkenhuysen et al. (2015, 2017), IEAGHG⁷ (2016) and Lindeberg et al. (2017) have studied the general potential and economics of CO₂-EOR in the North Sea. In the UK offshore sector at least three projects were considered for CO₂-EOR (Malone et al., 2014). However, no projects have progressed past the feasibility stage mainly due to economic factors, but also due to the lack of sufficient volumes of CO₂. In order to enable large-scale CO₂-EOR in the offshore sector, it is

⁵ NPD = Norwegian Petroleum Directorate

⁶ SCCS = Scottish Carbon Capture and Storage

⁷ IEAGHG = IEA GreenHouse Gas R&D Programme

clear that initiatives to initiate CO₂ capture and supply infrastructure are needed (Markussen et al., 2002).

4. In the Gulf of Mexico, five CO₂-EOR pilots were carried out in Louisiana's shallow near-shore and bay waters in the 1980s. These were Quarantine Bay, Timbalier Bay, Bay St. Elaine Field, Weeks Island Field and Paradis Field. In all pilots the CO₂ was delivered to the injection site by barges where the CO₂ was injected followed by either nitrogen or field gas in a gravity stable strategy. All pilots were considered successful (Malone et al., 2014).
5. Other offshore investigations for CO₂-EOR have been performed for Abu Dhabi (Persian Gulf) and the South China Sea (SCS; Pearl River Mouth Basin; Huizhou 21-1 Field) (Malone et al., 2014). In general, the SCS opportunities are similar in technical aspects and original recovery percentages to the North Sea Basin, Gulf of Mexico, and Brazil, although the field sizes for SCS are somewhat smaller. SCS has favourable light oil compositions (low density and viscosity), relatively high porosity and permeability, and shallow water depth (CSLF, 2015).

2.4 Global technical potential for CO₂-EOR incremental oil and CO₂ storage

A range of methods are presently used to estimate potential for EOR and CO₂ storage. Direct comparisons of various publications are therefore difficult. The summary below gives a global overview based on the IEAGHG (2009) report where the same approach was used for all assessed basins. The estimates for some of the regions in IEAGHG (2009) have been updated but not necessarily with the same assessment methods. These later estimates are quoted without consideration as to the quality of the methods. If the cited reference indicates whether the estimates are technically or economically feasible, this is indicated in the summary. For consistency, we start with the global overview from IEAGHG (2009) and revert to more recent publications later in this section.

IEAGHG (2009) used formulas to estimate a CO₂-EOR recovery efficiency factor (EOR%) in percent of original oil in place (OOIP). Sandstone and carbonate reservoirs were considered separately and the formulas were derived by regression analysis using Advanced Resources Institute's (ARI) EOR performance and reservoir data for US domestic oil reservoirs, involving API of the reservoir oil and the reservoir depth. The average EOR% for all basins considered in IEAGHG (2009) was found to be 21%. The potential for CO₂ stored was estimated in a similar way.

According to IEAGHG (2009) the *technically* recoverable CO₂-EOR oil from fields in that assessment is 95,000 million barrels of oil (15.2 GSm³), with a potential for storage of 29.2 Gt CO₂, giving a ratio of tonnes CO₂/barrels of oil of 0.307.

The largest potential is indicated to be found in the Rub Al Khali basin in the United Arab Emirates (UAE), with a potential for stored CO₂ of 8.8 Gt and technical recovery of 28,000 million barrels of oil, followed by the Maracaibo Basin, Venezuela (4.5 Gt CO₂ and 14,300 million barrels of oil), and the North Sea (4 Gt CO₂ and 14,400 million barrels of oil). Note, however, that the North Sea estimate was based on 14 sandstone fields in the UK sector of the North Sea Graben Basin and did not include fields in the Norwegian sector. The Niger delta, Nigeria, was estimated to have the potential to store 3.1 Gt CO₂ and to produce an additional 10,400 million barrels of oil.

The estimates in IEAGHG (2009) for the US Gulf of Mexico (GoM) included only oil fields offshore the state of Louisiana. According to Vidas et al. (2012), this is where the majority of potential CO₂-EOR fields are located. Vidas et al. (2012) estimated the CO₂ storage potential from EOR to be 1.5 Gt CO₂, close to the estimate of IEAGHG (2009). However, a map in ISO (2017; draft only, to be published) indicates that the potential for CO₂ storage in EOR fields for GoM is as much as 14.2 Gt CO₂.

2.5 Regional updates of global technical potential

2.5.1 USA

Malone et al. (2014) used a reservoir model (CO₂-PROPHET) to estimate the potential additional oil recovery and CO₂ storage from CO₂-EOR in the Gulf of Mexico (GoM). The average EOR% was found to 18%, fairly close to the average in IEAGHG (2009). Using what was termed “current” CO₂-EOR technology, Malone et al. (2014) estimated the technical potential for incremental oil production and CO₂ storage to 23,500 million barrels of oil (3760 Sm³) and 12.64 Gt CO₂, which compares to 4,600 million barrels and 1.6 Gt CO₂ in Figure 2.3.

Malone et al. (2014) assessed the potential for CO₂-EOR for the GoM offshore oil fields using “current CO₂-EOR technology” and “next generation CO₂-EOR technology”. The latter is defined to consist of four “major” technological improvements over current CO₂-EOR technology:

- Improved reservoir conformance
- Advanced CO₂ flood design
- Enhanced mobility control and injectivity, and
- Increased volumes of efficiently used CO₂.

The results are shown in Table 2.1.

Table 2.1. US Gulf of Mexico technical oil recovery potential and associated CO₂ storage potential, current and “next generation” technologies

	Current technology	“Next generation “ technology
Total technical viable oil recovery (millions of barrels)	23,500	53,900
Total CO ₂ demand/storage capacity (Gt)	12.64	15.1

2.5.2 North Sea

In the North Sea, field gas is used on a large scale for enhanced recovery, with total volumes of gas of the order of 35 Gm³/yr (Cavanagh and Ringrose, 2014). However, there are no fields that use CO₂ for EOR. One of the key challenges for CO₂-EOR in the North Sea is that existing gas-based recovery methods offer economically and technically attractive solutions, reducing the potential benefits of CO₂-EOR, especially if additional facility conversion costs are taken into account.

Pershad et al. (2013) estimated the theoretical incremental oil production using CO₂-EOR in the North Sea assuming it will be 10% of OOIP. Using this approach on 19 fields in the UK sector, nine in the Norwegian sector, and two in the Danish sector Pershad et al. (2013) estimated the potential for incremental oil production in barrels and CO₂ storage in tonnes. Their results were updated by IEAGHG (2016) with incremental oil production for 12 fields in the Norwegian sector, including eight from Pershad et al. (2013) but given in Sm³ (for the UK sector they used the same 19 fields as Pershad et al. (2012), but with volumes in barrels). Table 2.2 summarises the results using the following assumptions:

1. In the UK sector all numbers are from Pershad et al. (2013)
2. In the Norwegian sector incremental oil production is from IEAGHG (2016) + one field (Tordis) from Pershad et al. (2013)
3. Conversion factors 1 barrel = 0.16 Sm³
4. In the Norwegian sector a CO₂/oil ratio = 0.25 tonnes/barrel excluding Staffjord and 0.27 including Staffjord as the average of numbers from Element Pershad et al. (2012).

Table 2.2. Potential incremental oil production and CO₂ stored from applying CO₂-EOR in the North Sea (Combined data from Pershad et al., 2012, and IEAGHG, 2016). Conversion used: 1 barrel = 0,16 Sm³, CO₂/oil ratio = 0.25 tonnes/barrel excluding Statfjord and 0.27 including Statfjord in the Norwegian sector

Sector	Incremental oil production, from CO ₂ -EOR, million Sm ³	CO ₂ stored during EOR (Mt CO ₂)
UK (all numbers from Pershad et al. (2012))	From 403* to 496	From 852* to 1031
Norway (oil production from IEAGHG (2016) + Tordis field from Pershad et al. (2013) and stored CO ₂ using factors as given in caption)	From 577** to 679	From 1082** to 1273
Denmark (all numbers from Pershad et al. (2013))	62	109
TOTAL	From 1042*** to 1237	From 2043*** to 2413

*Excluding Brent and Miller, which are known to be unsuited for or have significant challenges with CO₂-EOR

** Excluding Statfjord, which is known to be unsuited for or have significant challenges with CO₂-EOR

*** Excluding Brent, Miller and Statfjord

Thus the incremental oil production, from CO₂-EOR and the CO₂ stored during EOR in the North Sea according to Table 2.2 (Pershad et al., 2012) is half of what IEAGHG (2009) estimated (Figure 2.3). This is probably due to the assumption in Pershad et al. (2013) that the incremental oil is 10% of OOIP, whereas IEAGHG (2009) and Malone et al. (2014) used derived values of 21% and 18%, respectively.

In a recent study by Karimaie et al. (2016) simulations using a realistic model of a North Sea oil reservoir were used to assess the performance of CO₂ injection for oil recovery compared to a base case water injection. This study demonstrated the importance of the well design with a range in incremental oil from close to zero (for vertical well) and up to 8% (for a horizontal well).

2.5.3 Other basins and revised global potential

Figure 2.3 shows basins for which the potential for incremental oil production and CO₂ storage have been assessed by IEAGHG (2009), Malone et al. (2014) and ISO (2017; draft only, to be published).

ISO (2017; draft only, to be published) included numbers offshore California, Jeanne d'Arc, Bohai Bay, Pearl River Mouth and Beibu Gulf and Malone et al. (2014) assessed all fields in the Gulf of Mexico. Table 2.3 shows the potential for incremental oil production and CO₂ storage for all assessed basins.

If numbers Table 2.3, i.e. including the numbers from ISO (2017; draft only, to be published) and Malone et al. (2014) are added, the total global potential for CO₂ stored amounts to 41.2 Gt CO₂. With the same ratio of technically recoverable oil to injected CO₂ in the basins where incremental oil has not been estimated as for those where it has been estimated, the potential should be an extra 117 100 million barrels.

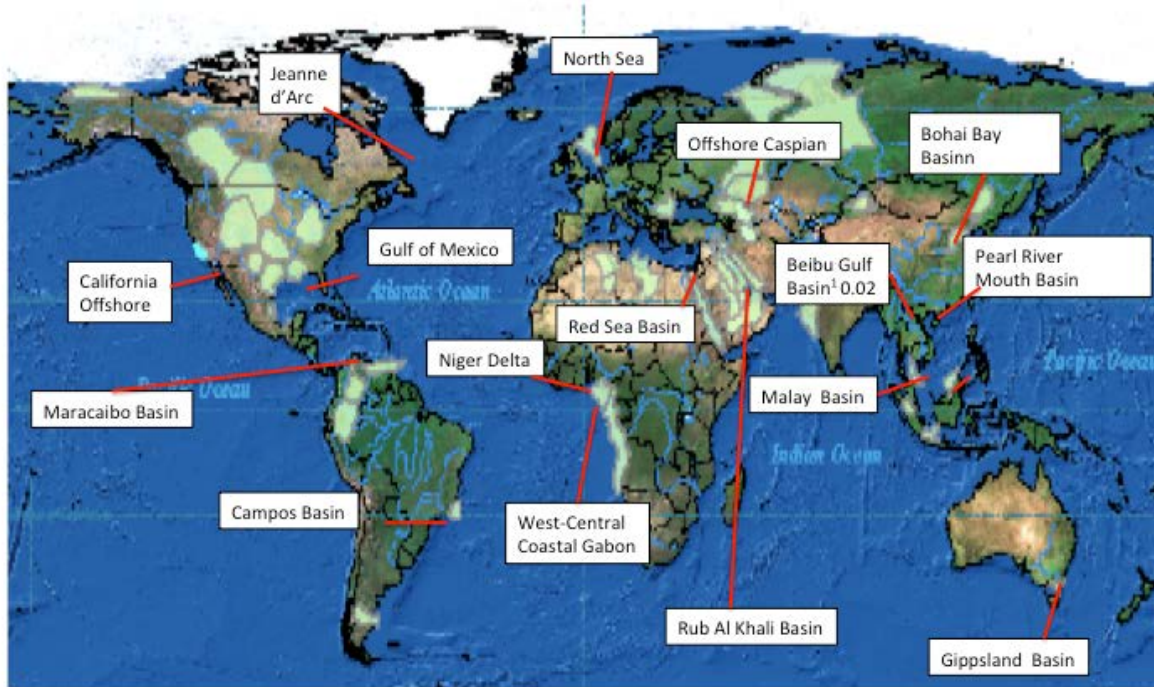

Figure 2.3. Basins for which the potential for incremental oil production and CO₂ storage have been assessed, see Table 2.3

Table 2.3. Potential incremental oil production and CO₂ permanently stored in the basins shown in Figure 2.3.

Basin	Incremental oil, million barrels	Stored CO ₂ , Gt
Rub Al Khali*	28000	8,8
North Sea*	14400	4,0
Maracaibo*	14300	4,5
Gulf of Mexico **	23500	12,6
Niger Delta*	10400	3,1
Offshore Caspian Sea*	8700	2,6
West-Central Coastal Gabon*	4000	1,3
Campos*	3100	1,1
Red Sea*	3100	1,0
Baran Delta/Brunei-Sabah*	1900	0,6
Gippsland*	1300	0,3
Malay*	1300	0,3
Jeanne d'Arc***		0,7
California Offshore***		0,2
Bohai Bay***		0,1
Beibu Gulf***		0,0
Pearl River Mouth***		0,0
Total	114000	41,2

*IEAGHG (2009)

** Malone et al. (2014)

*** ISO (2017; draft only, to be published)

2.6 Economics of offshore CO₂-EOR

Several factors will play together to decide the profitability of offshore CO₂-EOR projects. Some are global and/or regional in scale, some project and site specific. Table 2.4 lists some of the factors and they will all influence the cash flow of the project.

Table 2.4. Some key input parameters to CO₂-EOR profitability studies and their relevant scales

Oil price	Global
CO ₂ emission cost	Global/ Regional
CO ₂ availability, price, incl. transport	Regional local or project specific
Reservoir characteristics (incl. permeability, depth, API)	Site specific
Start of CO ₂ -EOR operation	Project specific
Project discount rate	Project specific
Lost production during rebuild and delayed decommissioning cost	Project specific
CAPEX, (incl. modifications, wells, recycling of CO ₂)	Project specific
OPEX (incl. separation and compression of CO ₂)	Project specific
Regulatory issues, monitoring, decommissioning, closure* and liability	Project specific

* Closure is used as a period that extends beyond the close down of the project or end of oil production (termination).

Some further comments to these factors are worth mentioning here:

1. Availability of CO₂. There are few, if any, developed sources of CO₂ close to the offshore fields amenable to CO₂-EOR. Holt et al. (2009), Kemp and Kasim (2013), Malone et al. (2014) and Lindeberg et al. (2017) all assume that an infrastructure that collects CO₂ from several sources and transports it to a number of oil fields is in place. Building an infrastructure will require huge up-front investments and the coordination of several stakeholders. A one-on-one source to CO₂-EOR field is likely to be more expensive per tonne CO₂ than a network, and have low flexibility with respect to reduced need for fresh CO₂ and temporary stops in the CO₂ production.
2. Price of CO₂ delivered at the fields for EOR. This will include transportation costs, either as cost for building a one-on-one pipeline or tariff costs in a network. In addition comes the price the oil field operator must pay to the CO₂ supplier. This will often be subject to negotiations between seller and buyer and could be influenced by CO₂ prices in a trading scheme.
3. Timing of the EOR operation. The effect of CO₂-EOR will be reduced as the field gets more mature and at some point the benefit will be reduced. A UK study has shown the importance of “window of opportunity” (Energy Research Partnership, 2015). A slow development of CCS will delay opportunities for offshore CO₂-EOR.
4. High investment costs. Break-through and recycling of CO₂ will require significant modifications and additional equipment on the platforms to separate CO₂ from the produced oil and gas and also to make existing well and pipes resistant to CO₂ corrosion. CAPEX may come down if technologies are developed that reduce the need for modifications and new equipment, for example better mobility control or sub-surface separation system. Use of existing pipelines may also be a way to keep investment costs down.
5. Additional operational costs, OPEX, will result from the need to separate and recompress the recycled CO₂. New technologies are likely to reduce also the OPEX.
6. Reservoir characteristics are usually well known for mature oil fields but there will still be uncertainties around reservoir performance and the potential for additional oil yield.

7. Loss of production while modifying will represent an addition to high up-front costs. The shorter time needed for the modifications the lower will the production loss be. The value of the production loss is also dependent on the required rate of return.
8. Uncertainties around regulations. Although CO₂ for offshore EOR is considered a commodity under the London Protocol (see Chapter 6) it is not clear what requirements different jurisdictions will place on monitoring the CO₂ in the underground, both during and particularly after closure and if the field transfers into a CO₂ storage field.
9. Uncertainties around the revenues, which are the oil price and the cost of CO₂ emissions. Low oil prices and high CO₂ cost for the operators will prevent offshore CO₂-EOR unless new business models and/or changed tax regimes are implemented to de-risk investments.
10. Assumptions on the rate of return (ROR) on the investments or the discount rate used. This varies at least between 7% (Lindeberg et al., 2017) and 20% (Malone et al., 2014). The choice or requirement will have a significant impact on the net present value (NPV) and the profitability of a CO₂-EOR project.

A number of studies have been performed on the economics of offshore CO₂-EOR, mainly in the North Sea and Gulf of Mexico (Holt et al., 2009; Kemp and Kasim, 2013; Lindeberg et al., 2017; Welkenhuysen et al., 2015, 2017; Pershad et al., 2012, 2014; Vidas et al., 2012; Malone et al., 2014). Different assumptions regarding key parameters, as listed in Table 2.4, make it difficult to systemise and/or compare results from the studies. However, a typical cash flow will show large expenses and no real income the first few years, hereafter many years with net oil revenues and expenses, mainly in terms of OPEX and tax, as illustrated in the artificial example in Figure 2.4 (based on examples in Welkenhuysen et al., 2015; and IEAGHG, 2016). In reality, there will be more factors to include, such as deferred commissioning, and the CO₂ may even become an income rather than an expense.

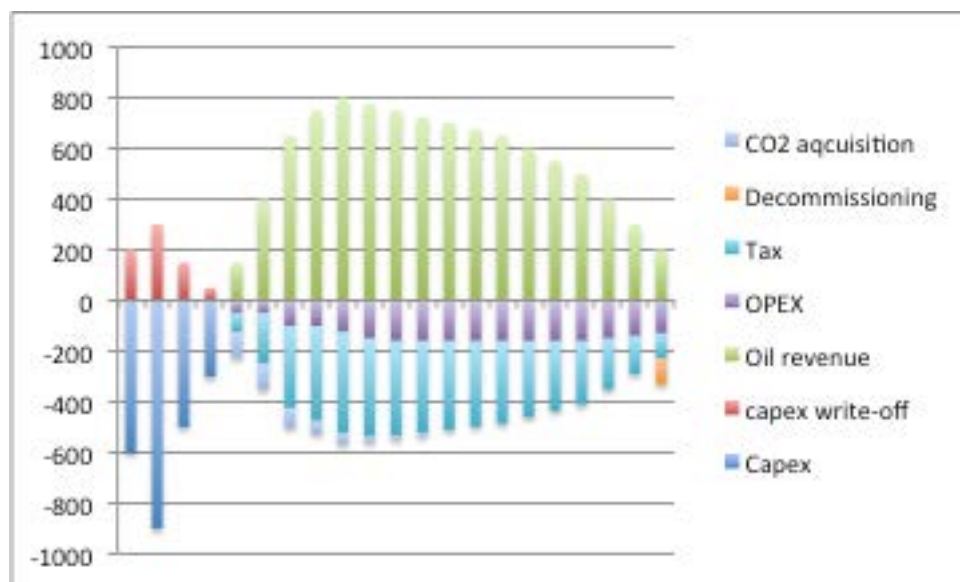

Figure 2.4. Possible cash flow in an offshore CO₂-EOR project. All numbers are fictitious but the presentation form is based on examples in Welkenhuysen et al. (2015) and IEAGHG (2016). In reality there will be more factors to include, like deferred commissioning.

Malone et al. (2014) made certain assumptions regarding cost input to an economic model. They used a ROR of 20% and CO₂ injection was terminated when NPV for a field became negative. This resulted in a significant reduction in viable oil recovery, as illustrated in Figure 2.5 and by comparing Tables 2.1 and 2.5. “Next generation” technology improved the viable recovery by a factor of 18 for the low oil price and 13 in the high oil price scenario.

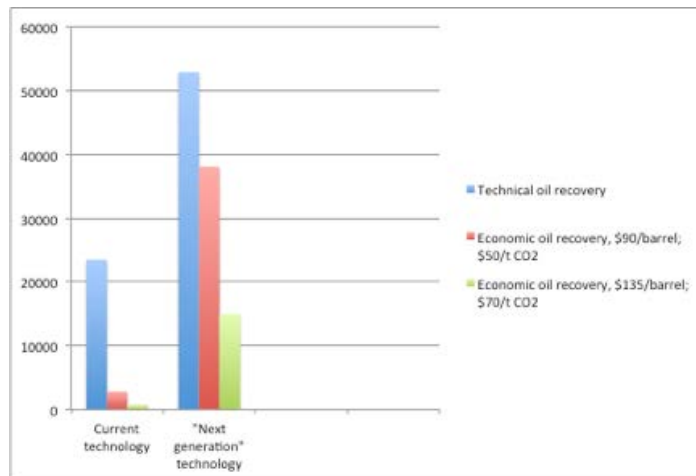

Figure 2.5. Gulf of Mexico oil recovery potential with current as well as “next generation” technology (After Malone et al., 2014)

IEAGHG (2016) used a different economic model, different assumptions regarding CAPEX and OPEX than Malone et al. (2014) and a ROR of 12% to estimate the economics of CO₂-EOR in the North Sea. One of the key messages from IEAGHG (2016) was that

“Investment in CO₂-EOR is highly constrained by the volatility of the price of oil. For EOR projects to remain profitable over their operational life the cost of supplied CO₂ supplied needs to fluctuate. One example from this study, based on the North Sea, shows that the cost of CO₂ could be ~35 €/tonne if the price of oil reached US\$150/bbl but it would need to drop to ~2 €/tonne if the price of oil fell to US\$50/bbl.”

Table 2.5. US Gulf of Mexico economic oil recovery and associated CO₂ storage potential, current and “next generation” technologies

	Current technology	“Next generation “ technology
Total economic viable oil recovery (millions of barrels)	810*/2,820**	14,920*/38,060**
Total CO ₂ demand/storage capacity (Gt)	0.3*/1.14**	3.9*/10.7**

* Oil price \$90/barrel; CO₂ price \$50/t

** Oil price \$135/barrel; CO₂ price \$70/t

Welkenhuysen et al. (2015, 2017) used a techno-economic simulator (PSS IV) to assess the viability of CO₂-EOR in the North Sea that included technological, policy-related, economic and geological uncertainties using Monte-Carlo calculations and a discount rate of 10%. For the Claymore field the conclusions were

“In general, CO₂-EOR projects, especially when joined with CGS (CO₂ geological storage), can be profitable at low oil prices. Oil price is, however, not the only determining factor. With oil prices below 40-50 €/bbl, a fairly high CO₂ revenue is necessary to enable EOR. The CO₂ revenue has only a minor influence on the EOR phase itself, but when followed by CGS, a sufficiently high CO₂ revenue can result in an almost risk-free investment. At a CO₂ revenue of 17€/t, a CGS phase after oil production has ceased becomes economically interesting.”

Welkenhuysen et al. (2015, 2017) also found that that geological uncertainty is an important factor for determining the economic threshold level of an EOR project, and a proper assessment of the real uncertainties can make the difference between profit and loss.

3 Insights from LULA project – the World’s first Offshore CO₂-EOR project

3.1 Background

Lula supergiant field was discovered in 2006, in the area known as Santos Basin Pre-Salt Cluster (SBPSC), southeast Brazil. It is located in deep waters (2200 m), approximately 230 km from the coast (Figure 3.1) and occupies about 1523 km². Reserves are estimated in 5-8 billion barrels. It is developed by a joint venture composed by Petrobras (65%; Operator), BG E&P Brasil/Shell (25%) and Petrogal Brasil (10%).



Figure 3.1- Location of the Lula Filed (red cross)

The origin of Lula’s main reservoirs is related to the tectonic process of Gondwana separation, 160 million years ago, giving place to the South American and African continents. The rift phase created the conditions for the deposition of terrestrial and lacustrine sediments on the space between the two continents. As the separation continued, seawater began to fill that gap, creating a low energy and high salinity environment that was favourable to the growth of special bacterial colonia, such as stromatolites. The secretion of these microorganisms, together with the precipitation of carbonate salts, created nucleous to form carbonate rocks, known as aptian microbialites, where the oil in the pre-salt was discovered. Later on, due to a severe climate change on earth, the huge amounts of salt once dissolved in the seawater of this low energy environment precipitated, generating a 2000 m-thick salt layer that became a perfect seal for the hydrocarbon that migrated into the microbialites.

The oil has a good quality (28-30 API) and contains a significant amount of associated gas (gas oil ration, GOR, 200-300 m³/m³). The CO₂ content in this associated gas is around 11%.

The main challenges for Lula field development were mapped in the very beginning:

- Ultradeep waters.
- Heterogeneous carbonate reservoirs.
- Presence of contaminants in the associated gas, mainly CO₂.
- Thick salt layer & very deep reservoirs. Besides the drilling difficulties, these characteristics also imposed additional seismic imaging complexities

This unique combination of technical and logistic challenges created the opportunity for the development of new solutions and technologies.

Since the early stages of Lula field development, studies were conducted to evaluate options to achieve a high ultimate economical recovery. EOR issues were addressed from the very beginning of its life cycle.

A screening study was performed and several methods were considered. As there were many limitations for offshore EOR in terms of logistics and plants for fluid injections, chemical processes

were considered unfeasible. Hence, offshore EOR for Lula would have to take advantage of the only two somehow abundant resources available: seawater and the produced or imported gas.

Lula scenario is particularly suited for miscible gas methods. The relatively low reservoir temperatures (60 to 70°C) and the high original reservoir pressure allowed forecasting an efficient miscible displacement process of the oil by enriched CO₂ streams or even by hydrocarbon gas (HC). Preliminary numerical simulation results indicated that a substantial incremental recovery could be attained by CO₂ or CO₂/HC EOR in secondary or tertiary modes.

Considering CO₂ injection as a potential recovery method for Lula benefits from the aforementioned high GOR and CO₂ concentration present as contaminant in the reservoir fluids, as well as from the strategic decision not to vent CO₂ to the atmosphere. This last point was perhaps the most important driver, as it somehow dictated the whole field development conception.

As the available CO₂ volume may not be enough for a full field application, an option is to select a specific region of the reservoir to be developed with CO₂-EOR or to re-inject all the produced gas (HC plus CO₂), which could be done in the whole reservoir extent. Water-Alternating-Gas (WAG), as a way to control the adverse gas mobility, could be an effective option to maximize oil recovery potential.

To comply with the decision of not venting the CO₂, a solution based on the purification of the produced gas and reinjection of the CO₂-rich stream either in discharge wells or Water-Alternating-Gas (WAG) injectors was adopted. In fact, the facilities were designed with the flexibility to inject an enriched CO₂ stream or mixtures of CO₂ and hydrocarbon gas. In the case of injecting a CO₂-enriched stream, WAG acts more as a reservoir management strategy than as an EOR mechanism, due, as previously mentioned, to the relatively low global amount of CO₂ available.

Other important drivers for field development were also established:

- Phased development, dynamic data acquisition and actions to add robustness/flexibility to the production system and manage uncertainties. Phased development concept aimed at risk mitigation, optimization of production systems and also expenditure versus revenue balancing, coupling information acquisition with cash flow acceleration.
- Multi-well production pilots. The early operation of pilot projects provided valuable information not just for conventional waterflood recovery, but also for future EOR by WAG injection.
- Comprehensive analysis of the existing uncertainties, such as: reservoir characterization, early water and gas breakthroughs, bypassed oil saturation, flow assurance in deep water flow lines, CaCO₃ scale possibility in production wells.
- Definitive systems incorporating the knowledge acquired through the previous phases and prioritizing the standardization of wells and production systems.
- CO₂-EOR planned in advance. As offshore projects need to be planned well in advance, due to the lack of room in the platforms and prohibitive costs for future expansions, the pioneer application of EOR methods needs to be considered from the conceptual stage of the development.

Following this strategy, Lula field development was subdivided in three phases, as described below:

- Phase 1: Information acquisition.

Drilling of appraisal wells, reservoir coring, well logging, fluid sampling and laboratory tests, high resolution seismic acquisition and interpretation, cased hole well tests, evaluation of different well geometries, test of different stimulation techniques and analysis of flow assurance issues.

In this stage, early production development projects were designed and implemented: Two

Extended Well Tests (EWT) and one pilot test.

- Phase 2: Definitive development, mostly applying conventional solutions (2012-2017).

Will comprise the deployment of one additional chartered floating production storage and offloading (FPSO) for production pilot Lula Nordeste (first oil in 2013) and the expansion of Lula pilot to evaluate the performance of waterflood, gas flood, and WAG. The gas can be a hydrocarbon gas, from the producing reservoir, or CO₂ originally contained in the associated gas, stripped in the FPSO processing plant.

- Phase 3: Definitive development, implementing non-conventional solutions in large scale.

In this phase the intention is to deploy non-conventional solutions, in a larger scale, aiming at cost reduction and production/recovery optimization.

The main consequences of this strategy to the field development will be briefly described in the following sections.

3.2 Reservoir Characterization

Proper static and dynamic characterization was a primary driver, not just because of the CO₂/HC gas reinjection, but also due to the expected reservoir complexity.

A comprehensive appraisal program was established in order to build the necessary framework for a complete definition of the development plan. It comprised, among other techniques, well drilling, core extraction, special core analysis, and well logging.

Special attention was dedicated to dynamic modelling by means of transient well testing and extended well tests (EWT). In the mid of 2010, Lula field started producing from its first EWT.

A production pilot project was initiated in Lula field by the deployment of a production system with a total of 9 wells (6 producers, 1 gas injector, and 2 WAG injectors). The main objective was testing the performance of different recovery methods.

Dynamic appraisal proved essential to assess reservoir connectivity, evaluate stimulation methods, support reservoir characterization studies, and define aspects related to flow in subsea lines.

New methods of seismic characterization of reservoirs were implemented, including high resolution seismic imaging and 4D seismic to monitor fluid motion and WAG injection.

Fluids characterization also received much attention, both in terms of their reservoir (PVT) and flow assurance properties.

An extensive program of downhole fluid sampling and laboratory experiments was established aiming at the identification of critical flow assurance aspects, such as wax, gelation, hydrates, asphaltenes and inorganic scaling. Besides evaluating the risks in the lab, some mitigation actions were taken, such as: adequate thermal insulation of risers and pipelines, flexibility in platforms to displace oil in flowlines by diesel during shutdowns, and implementation of downhole chemical injection systems (e.g.: scale & asphaltene inhibitors, H₂S scavenger).

Interwell gas and water multitracer injections and monitoring were performed. Perfluorocarbons and fluorobenzoates were, respectively, used. Being able to monitor the bottom hole pressure and the use

of chemical tracers in the injected fluids may provide important information to match the production history and calibrate simulation models.

Regarding specific tests for WAG injection, a broad laboratory characterization programme was launched to determine oil swelling, minimum miscibility pressures (slim tube and rising bubble), multiphase flow in porous medium phenomena particular of WAG floods, geomechanics, and rock-fluid interactions.

Reservoir studies comparing waterflood, considered as the reference case, with the application of gas-based EOR, CO₂ injection, and WAG were done by numerical simulation and laboratory tests. Equation of state (EOS)-based compositional simulation was adopted in all the cases in order to properly represent the fluids phase behaviour.

All surveys were supported by Value of Information studies (VOI), to balance the costs and time demanded by the characterization techniques with the alternative of providing flexibility to the development plan and production facilities. Some benefits of this extensive characterization programme were:

- Identification of vertical communication, permeability barriers and faults.
- Determination of saline aquifer actuation.
- Determination of the oil compositional variation in the field, allowing adjustments of production units' gas processing capacities.
- Optimization of well locations, redefinition of perforation intervals, and selective injection/production strategy based on reservoir characteristics and behaviour. It's important to stress that well reallocations were only possible due to the flexibility provided to subsea layouts.
- Optimization of FPSOs' locations due to revised geological and flow models calibrated with dynamic data.
- Conclusion on the absence of significant flow assurance issues due to wax, asphaltene, or severe inorganic scale.
- Guidance to well material selection.
- Confirmation of a very good performance of CO₂ separation process in the FPSO, using membrane technology.
- Confirmation of good water injectivity indexes.

3.3 Robust & Flexible Development Strategy

Even if adopting an aggressive strategy for data collection, it is normal that a high degree of uncertainty about the dynamic behaviour persists, not only by the huge dimension of the field, but also because of the complexity of the rock-fluid system. In addition, many properties regarding sweep efficiency, communication between regions and performance of dynamic mechanisms will be only disclosed during the full-field operation, when corrective procedures are more difficult to be implemented.

So, it is a wise decision to build a recovery strategy that will be profitable in different scenarios (robustness), even not being the best one for the most likely situation, and provide the project the necessary contingencies and resources to adapt the initial strategy if the operation reveals a behaviour different from the most likely case (flexibility).

Much of the reasoning behind this strategy is also associated to implementing EOR by WAG in the field. The complexity of implementing an offshore EOR project increases significantly as we move to ultra-deep waters. As the investments are normally huge, more appraisal and data acquisition would be

needed to reduce uncertainties and mitigate associated risks before sanctioning the project. However, due to high costs, information needs are usually balanced with the acceptance of a higher degree of risk or with an increased project flexibility. This context makes it extremely challenging to consider EOR application in this kind of venture. Usually, EOR methods require additional installation capabilities that can be prohibitive in an offshore facility, if they're not planned very well in advance. Besides, in early stages of development, every reservoir properties description presents several uncertainties. This is particularly true for the petrophysical properties distribution, even more critical in carbonate reservoirs, which usually present higher degree of heterogeneity than sandstones.

Some examples of how this robustness/flexibility strategy can be implemented are:

- Conversion of producers to injectors in case of compartmentalization
- Connection of additional wells
- Choice of injected fluid (gas, water or WAG)
- Adoption of selective injection by intelligent completion

3.4 Materials

A consequence of CO₂ presence in the produced fluids was the necessity of a careful definition of the materials to be used in wells, flowlines, risers and in the processing plant itself.

High pressures coupled to variable CO₂ contents make the use of carbon steel in wells, risers, and topside pipings nearly impossible. This issue is being tackled through use of Corrosion Resistant Alloys (CRA) and plastic-covered pipes. The combination of carbon steel and corrosion inhibitors in this case is not recommended, since it would be necessary to have products with extremely high efficiency and availability.

In response, an extensive laboratory study was launched in Petrobras R&D Center aiming to test different materials (metallic and elastomeric) able to withstand the high pressures and aggressive environment. A qualification program for flexible risers and subsea flow lines was also performed, in cooperation with the industry.

3.5 Intelligent Completion

To improve the reservoir management, intelligent completion was deployed whenever considered beneficial. Several factors may affect the decision to adopt or not adopt intelligent completion for each well, therefore, it is not always recommended to use this configuration. One of the aspects to consider is geological: to be effective, it is desirable to have vertical isolation between zones in the reservoir.

This type of completion can be an effective alternative to mitigate the risk of preferential flow and early breakthrough of injected fluids in the reservoir. The successful use of this feature, together with the flexibility to be able to inject either water or gas, in the injection wells, plus the capability to alternate the gas injection through different wells, will be providential to confirm the additional oil recovery expected by EOR implementation in the field.

Intelligent completion valves have been used for several purposes, including controlling gas production, performing well tests, splitting commingled injection or production and proactively managing water/gas breakthroughs.

First intelligent dual zones completion installations have been successful in pre-salt area, with no compromise to the project timeline or to the system performance. Considerable amount of improvements have been made on system design and installations procedures.

3.6 Production Units/Topside Facilities

Floating Production Storage and Offloading (FPSO) units were chosen as the best alternative to develop Lula field, mainly due to crude oil storage capability, not requiring the construction of long length oil pipelines, and also because of other characteristics that allow a short-term completion with economic advantages in an ultradeep offshore environment.

The topside processing plant design had to deal with uncertainties in the reservoir fluid compositions and production profiles in order to guarantee an adequate production capacity and also the proper performance within the established design cases. The units will be able to inject either desulphated seawater or the produced gas.

Simulation studies highlighted the importance of large capacity gas processing plants, considering that gas capacity could limit oil processing.

The technology chosen for CO₂ separation was permeation through membranes, once it was the only process identified that could be able to handle a wide range of CO₂ concentrations throughout the production life. As membranes are sensitive to heavy hydrocarbon condensates and aromatics, the FPSOs were also designed with a dew point control unit to remove heavy hydrocarbons upstream the membranes. At the time of the conceptual design, there were uncertainties related to the miscibility of the gas to be injected into the reservoir and its thermodynamic behaviour. In order to allow the evaluation of gas injection with both high and low levels of CO₂, the first topside facilities were designed with a CO₂ membrane system that provided two streams: a treated gas with low CO₂ content (5% v/v) and a stream with very high CO₂ content (up to 90% v/v).

3.7 Lula WAG pilot

Launching an EOR miscible process in a deep offshore carbonate reservoir was a major challenge. Some specificities of carbonate environment should be considered and some risks mitigated. To accomplish this task, a first pilot has been launched in 2011 (so-called Lula-pilot) and a second one in 2013 (Lula-NE).

One of the main objectives of Lula Pilot in terms of CO₂-EOR was the evaluation of some operational issues, such as:

- Early breakthrough in production wells
- Reduced injectivity (mainly water injectivity loss after gas cycles)
- Corrosion due to carbonic acid
- Scale deposition
- Asphaltene precipitation
- Wax deposition
- Hydrate formation upon WAG cycling

Additional information expected were:

- WAG performance

- Performance and benefits of horizontal drilling
- Improved understanding of Lula reservoir connectivity due to additional wells and more pressure tests
- Extended evaluation of gas processing plant and CO₂ removal system

Lula pilot was designed to allow WAG injection either by injecting produced gas (WAG-HC) or CO₂ (WAG-CO₂) or a mix of HC gas and CO₂. A total of nine wells were drilled, being six producers, one gas injector, and two WAG injectors.

The injection started in April 2011 (FPSO Cidade de Angra dos Reis), injecting around 1 million m³/d. The gas was mainly HC with some CO₂ content. From September 2011 on, the gas exportation system was started and since then part of the produced gas was separated from the CO₂ and exported to shore. The injection well started to inject mainly CO₂, with concentrations higher than 80% and injection rates around 350 km³/d. It was the first time a CO₂ rich stream was injected in an ultra-deep water well, equipped with subsea completion, to improve oil recovery.

Since all wells have downhole pressure gauges, the pressure is being monitored. Tracer (PFCs) monitoring on gas injection has been conducted since June 2011.

No major operational or reservoir problems have been detected so far. No gas or water injectivity losses upon cycling have been observed. No flow assurance issues, like hydrates, asphaltene or wax precipitation or severe inorganic scaling were seen. Injected perfluorocarbon gas tracers were easily injected and detected and are actively contributing to revise the geomodel.

Lula-NE pilot was conceived to test some new concepts for the production development in the Pre-Salt area. In terms of subsea gathering system, an innovative concept was deployed, combining flexible flowlines lying on sea floor, with rigid steel catenary risers (SCR) supported by a buoy positioned 250 m below sea level. The drainage plan considered eight oil producers, some of them with intelligent completion, one gas/CO₂ injection well, and five WAG injectors (two subsea WAG manifolds were also installed). A balanced approach between data acquisition and facilities flexibility made it possible to face the many reservoir and production uncertainties.

The chartered FPSO Cidade de Paraty started production in June 2013, with an oil capacity of 120,000 bpd, and a gas plant able to process up to 5 million m³/d of gas with 35% content of CO₂. Despite all the challenges, the project was delivered on time, with production plateau attained in September 2014.

Lula pilots' results are being essential to calibrate the simulation studies and select the best strategy to maximize the oil recovery and project's profitability. These outcomes will provide the basis for adopting the optimal strategy for field development in definitive systems. All the detailed planning and step-by-step achievements are paving the way for a consistent deep water EOR application.

4. Approaches for enabling offshore CO₂-EOR

Several studies have demonstrated that developing CO₂-EOR on a large offshore oilfield in the late-life development stage has many significant hurdles (ref section 2.2), which can be summarized in terms of:

- a. The large investment costs associated with conversion and adaption of offshore platform facilities;
- b. The lack of infrastructure to supply and handle sufficient volumes of CO₂ to achieve a viable CO₂-EOR project;

- c. Competition with other more attractive oilfield development options, such as gas injection.

In order to stimulate incremental growth of new offshore CO₂-EOR projects, various options have been proposed, including:

- Using smart operational solutions for reducing project CAPEX and OPEX
- Using late-life oilfield infrastructure
- Using isolated oilfield satellite projects for dedicated CO₂-EOR projects
- Focusing on CO₂-EOR for Residual oil zone reservoirs
- Improved modelling tools

These options are briefly reviewed below.

4.1 Smart solutions for offshore CO₂-EOR operations:

It may be possible to reduce these investment costs for new CO₂-EOR projects by developing “smart solutions” for offshore CO₂-EOR, such as by minimizing the need for conversion of surface facilities and optimizing the gas/CO₂ recycling system (Goodyear et al. 2011). For example, in the case of a CO₂ WAG development scheme the CO₂/water ratio can be adjusted to match the gas processing limitations. Martinez (1999) and Goodyear et al. (2011) also propose using CO₂ as an artificial lift gas in oil production wells in order to exploit the availability of CO₂ for field operations and at the same time reduce the overall project CAPEX.

4.2 Using late-life oilfield infrastructure

In certain cases, relatively minor modifications could be made to late-life, generally smaller, offshore field developments where some CO₂ handling capabilities are already in place. The K12-B gas field in the Dutch sector of the North Sea illustrates this potential. For most of the field life (since 1987) the field has been producing natural gas with a relatively high CO₂ content. Because CO₂ handling facilities were already in place, it was relatively cost-effective to turn the project into a CO₂ injection project as part of an R&D pilot project (Kreft et al. 2006). Although this project is not an EOR project it has been used to test storage and enhanced gas recovery concepts, and illustrated the potential for further use of offshore sour-gas field infrastructure for CO₂-EOR.

4.3 Using isolated oilfield satellite projects for dedicated CO₂-EOR projects

There is considerable experience now with sub-sea satellite field developments tied back to a main offshore oilfield project. One example from the Norwegian offshore sector is the Norne field, (Steffensen & Karstad, 1996) where satellite fields have been developed using subsea tie-backs to the main field developed using a FPSO (Figure 4.1). Using this concept the field development group has been able to apply effective and advanced reservoir management methods (Osdal & Alsos, 2010) to optimize both the main field and the satellite field developments. This example illustrates the potential for using an enhanced recovery technique such as CO₂ EOR on an isolated satellite field without incurring the larger conversion costs associated with a full field project, and offers a basis for identifying future opportunities for offshore CO₂ EOR pilot projects.

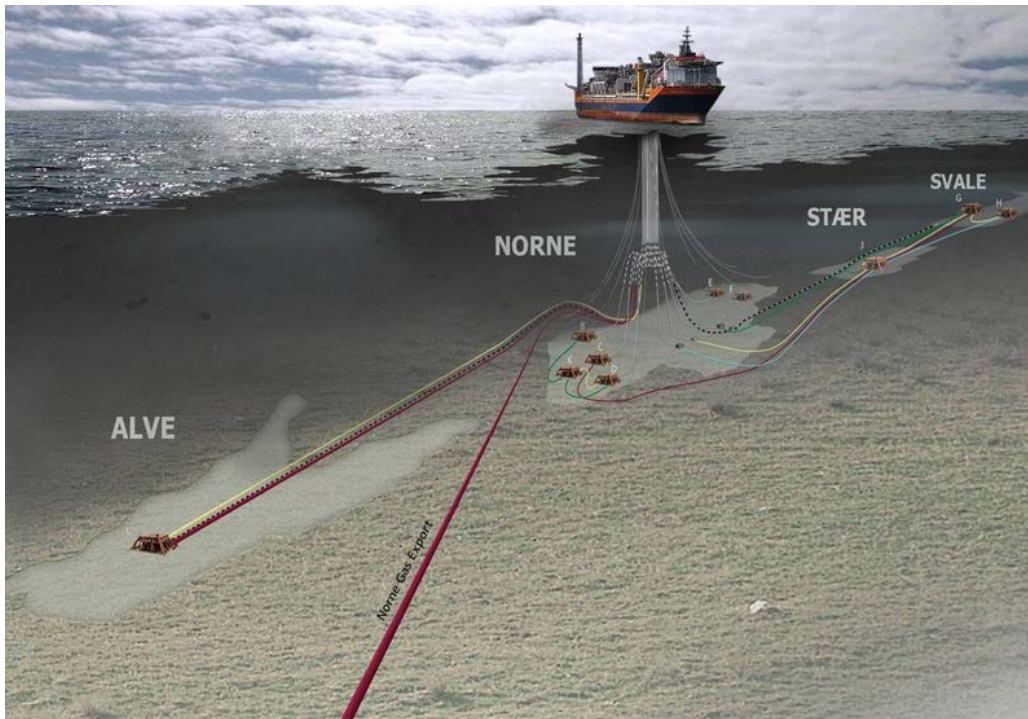

Figure 4.1. Illustration of the subsea satellite fields Alve, Stær and Svale developed by tie-back to the main Norne field (photo courtesy of Statoil ASA)

4.4 Focusing on CO₂-EOR for Residual oil zone reservoirs offshore

Residual oil zones located below oil/water contacts of many oil reservoirs have been identified as a significant new resource that could be realized using CO₂-EOR (e.g., Melzer et al. 2006; Harouaka et al. 2013) especially in the onshore Permian Basin of the mid-USA. A similar potential is found offshore (e.g., Stewart et al. 2014) and although even more challenging than the corresponding onshore resources, offshore ROZ reservoirs could be attractive as a combined CO₂ storage resource with an associated oil recovery benefit. Studies on CO₂-EOR potential in Residual oil zone reservoirs offshore are currently in the early screening stages.

4.5 CO₂-EOR Reservoir Modelling, Simulation and Optimization Issues

Reservoir mathematical modelling and simulation is a broadly used tool in the oil industry. Examples of common decisions nowadays taken by oil companies with the help of numerical simulation are, among others:

- Decision of type, number, and location of producer and injection wells.
- Prediction of production curves (volumes of produced oil, gas, water, CO₂, versus time).
- Demand for water/gas/CO₂ for injection.
- Number of production units (platforms).
- Size of topside treating facilities (e.g.: water/gas/oil treatment, water/gas overboarding, compression/pumping, reinjection, etc.).

The conscious choice to use mathematical simulations to make these prominent decisions is due to the fact that it is impractical to test all those variables at field scale in a timely and effective manner, particularly for the offshore development. Conventionally, a long chain of scientific disciplines and professionals were, and are, involved to perform this task with the best techniques available. As

mentioned elsewhere in this report, economics and overall uncertainties involving offshore CO₂ EOR is very important, directly impacting the feasibility of most of the projects.

In this context, properly modelling and simulating the process at field scale, from the reservoir-rock point of view, becomes an issue that still needs to be overcome.

This happens because CO₂-EOR is more complex than conventional recovery techniques. In other words, a greater diversity of physical phenomena needs to be characterized and represented in mathematical models/simulators in order to adequately describe and predict the behaviour of the process. Some examples of particular issues related to CO₂-EOR are:

- Phase behaviour. All thermodynamics and mass transfer phenomena involved in gas/CO₂ injection in oilfields impact the overall efficiency of the process. Equations of State and compositional fluid models are usually necessary to represent, for example, the amount of each phase and of CO₂ in different phases in each part of the field. Phase property variations particularly with temperature variations is more important to model in CO₂ injection compared to conventional hydrocarbon gas injection.
- Reaction with reservoir rock. CO₂ in the presence of water generates carbonic acid, that is known to react with carbonate cements or carbonate rocks, dissolving it at different grades, possibly impacting the flow (e.g.: fracture and channel generation/plugging, permeability/porosity change) and the production (e.g.: scaling).
- Multiphase-flow in porous media phenomena. Especially when sophisticated injection modes are used, like Water-Alternating-Gas (WAG), multiphase flow in porous media phenomena may arise that can significantly impact how water, gas, and oil flow in the reservoir rock and are produced. Examples are three-phase relative permeability and relative permeability/capillary pressure hysteresis.
- Oil Instability. Solvents like CO₂ may, in certain circumstances, destabilize some oil components, like asphaltenes. It can also impact the flow properties of the reservoir rock.

The central problem is that this complexity is not easily incorporated in commercial or even proprietary simulators. Moreover, upon implementation of these models, simulation time increases considerably, especially in big fields like those usually developed in offshore environment.

Demanding and time-consuming simulation runs would require simplifications of the models, so that reservoir studies and optimizations can be accomplished within the timeframe of commercial development. But this action can have tremendous impacts on the overall development plan and economic forecasts, including CO₂ demand, storage, treatment, and reinjection.

So in order to guarantee better and more predictive offshore CO₂-EOR projects it is highly recommended that the involved actors invest in proper characterization, modelling and simulation R&D, as well as in adequate computational hardware and new generation software that can accomplish the task of better representing the relevant phenomenological aspects of the process in increasingly bigger and more complex fields.

4.6 Application of numerical reservoir simulation in CO₂-EOR

In conventional hydrocarbon production, the decision on injection type, injection location, rate of injection, and injection duration is mainly reached using numerical reservoir simulation. Results obtained from such simulation studies make the basis for development of the injection strategy. While at least for mature fields existing experience can largely be used to decide on producers.

Decision on injection strategy in CO₂ EOR projects follows the same principle. Reservoir simulation results are needed to rank various scenarios based on recovery and cost estimates associated to each development plan.

Behaviour of injected phase in the reservoir in terms of local, vertical and areal sweep efficiencies and residual oil saturation behind the injection front dictate the ultimate recovery. In offshore development, due to much lower well density compared to land operations, application of mobility control techniques is needed to increase the sweep efficiency. Consequently, the injection of pure CO₂ as the sole injection strategy is highly unlikely. CO₂ Water-Alternating-Gas (CO₂ WAG), CO₂ Simultaneous-Water-And-Gas (CO₂ SWAG) or CO₂ foam injection techniques should be studied to increase the recovery. This is especially important regarding the high cost associated with offshore CO₂-EOR.

The following table shows the result of a simulation study on a generic North Sea reservoir. Various injection strategies are studied for this reservoir for a development plan based on single injector and a single producer (Karimaie et al., 2016). An interesting observation in this study is the effectiveness of common water flooding outcompeting CO₂ injection. The reason is poor sweep efficiency of injected CO₂ due to segregation in the reservoir. The recovery is maximized by increasing sweep efficiency either through the use of sophisticated well design or application of CO₂ mobility control techniques.

Table 4.1. Comparison of oil recovery factor using various injection techniques in an off-shore reservoir.

Case	EOR volume, $\Delta\Delta\text{MSm}^3$	Δ RF, %
Water injection	0.00	0.00
Continuous CO ₂ injection, horizontal well	1.30	8.44
Continuous CO ₂ injection, vertical well	-0.32	-0.5
Water-flooding followed by CO ₂ injection	0.36	3.23
Water-flooding followed by WAG injection	0.22	2.66
Water above gas SWAG injection	1.01	6.86
SWAG co-injection	0.66	4.91

5. EMERGING TECHNICAL SOLUTIONS FOR OFFSHORE CO₂-EOR AND STORAGE

5.1 Introduction

There are no fundamental differences in onshore and offshore CO₂-EOR. Reservoir and well conditions are different, but theoretically there will be the same requirements to treatment and separation onshore and offshore. There are, however, special challenges related to offshore treatment of well streams from an EOR flood. Existing offshore facilities generally have very limited space and weight reserves and the materials utilized in existing processing systems are generally not suitable for streams with a high CO₂ content. Production delays due to installation of facilities will have considerable negative impact on the economy of CO₂ injection project.

Several studies have concluded that to avoid retrofitting major parts of an existing processing train the best solution is to remove most of the CO₂ before the production fluid enters the processing system for further treatment. Studies are underway to address this issue by designing and manufacturing compact CO₂ separation systems that can be installed on seabed or on production platforms that would handle processing of the produced CO₂. A robust design is needed for such separation facilities, especially if

they are designed for installation on the seabed. The exact requirement for CO₂ content would be facility dependent. Variations in material quality of existing equipment, amount of gas and CO₂ content from fields not using CO₂-EOR, etc. will influence the requirements. A wide range of fluid compositions are expected during the lifetime of a CO₂-EOR project from pure hydrocarbons to increasingly higher CO₂ concentrations. Production wellhead conditions are variable making design of a robust compression system challenging.

In this chapter some options are presented:

- Adding a CO₂ processing module to separate CO₂ for reinjection.
- Using CO₂ rich gas together with oxy-fuel technology to generate power and to re-inject the flue gas, which is mainly CO₂ and water.
- Improved mobility control using CO₂ foam.

The development of compact equipment that can be used in a CO₂ processing module may enable the use of CO₂-EOR. Use of compact equipment may make it feasible to install on facilities with limited space and weight reserves. For some fields a CO₂ processing module can be placed on an external structure. Alternative external structures include jacket, jack-up rig, FPSO, or subsea modules. A new CO₂ processing module could also contain equipment for treating and boosting produced water for reinjection. This would free up capacity in the existing produced water treatment system which is usually a bottleneck on mature installations.

As an alternative to CO₂ separation, developments are ongoing to enable use of the CO₂ rich natural gas directly as fuel in power turbines. The technology is further described in chapter 5.4.2.

There is limited public literature available that have studied the impact of bringing CO₂-EOR offshore. However, some studies have analyzed the impact both on the well separation train, gas injection system, safety issues, material concerns and other related topics arising from handling well streams from a CO₂-flooded reservoir. Not all of these aspects are referred to here, but the most important topics have been considered.

A CO₂-EOR phase will typically have a duration limited to a few years. After the blow down phase, reservoirs may be used for permanent storage. Reuse of CO₂ processing equipment should be considered, either at another field or for injection of CO₂ for permanent storage.

5.2 Topside solutions

5.2.1 Goodyear study

Goodyear et al. (2011) refer to the modified well streams that typically will be caused by the CO₂ flooding, characterized by e.g.: high water cuts and high CO₂ concentrations, up to 90 vol %, in the gas phase. Especially the gas treatment facility, which includes gas dehydration (TEG contactors) and NGL recovery, can be very challenging. The weight of the complete treatment modules has been estimated to be between 6,000 and 16,000 tons. This drives the need for very efficient and compact solutions for the gas treatment equipment.

Goodyear et al. (2011) explain that the need for gas dehydration is driven by constraints in the downstream pipeline material. Further, there are various options for treating the recycled gas with respect to the degree of removal of hydrocarbons. Consequently, the recycled gas will alter the composition compared to the pure CO₂ used from external sources. This change in composition may have an impact on the performance of the EOR flooding efficiency since various impurities may affect the minimum miscible pressure (MMP).

Goodyear et al. (2011) also mention that offshore CO₂ concept selections have concluded that recovery of methane with current technology is not an attractive option. This is due to the high

demand for extractive distillation and corresponding high CAPEX. New technology concepts based on cryogenic principles and membrane separation are said to provide solutions for more favorable offshore CO₂-EOR projects.

5.2.2 Salim study

Salim et al. (2012) have studied a variety of implications of bringing CO₂-EOR offshore and using existing topsides facilities for this kind of operation. The areas affected are illustrated in Figure 5.1 below.

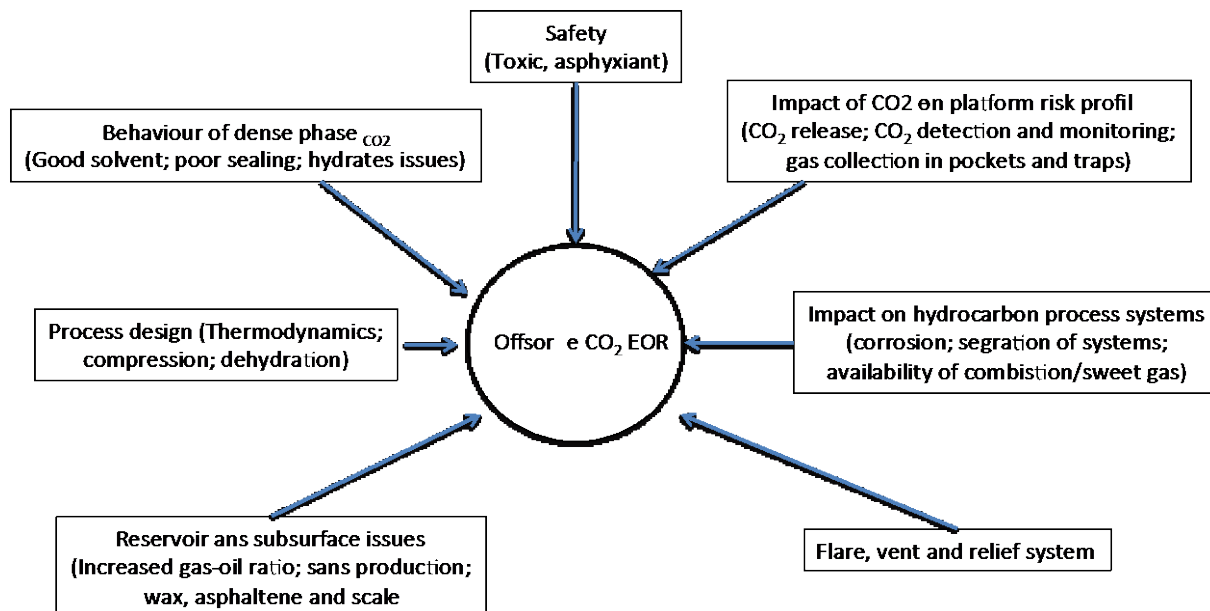

Figure 5.1. Areas that are affected on topsides facilities by introducing offshore CO₂-EOR. Based on an illustration by Salim et al. (2012)

The concept used in Salim et al. (2012) is based on a typical topsides facility in the North Sea. The study concluded that there is a need to install a completely new CO₂-EOR module with a bridged link to the host platform. This arrangement was chosen due to the impact of the corrosive nature of CO₂ to the existing facilities. The new EOR module would then communicate with the host platform by pumping the liquids in pipes between the units. The flow diagram of the EOR module is shown in Figure 5.2 below.

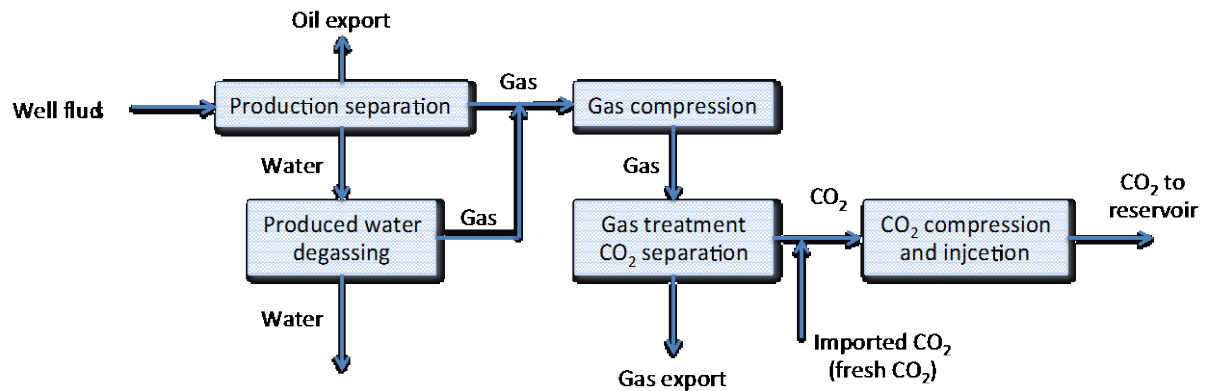

Figure 5.2. Schematic diagram of processing facilities on a new topsides EOR module. Based on an illustration by Salim et al. (2012).

As shown in the flow diagram, no recovery of NGL's or hydrocarbon gas is taken into account in this arrangement. However, a strong attention is made to the conditions for preparing drying of the CO₂ rich gas stream and analysis of contactor conditions for this operation is made. Water content in the dried gas is specified to about 105 ppmv and is regarded to be low enough for "dry" operation of downstream HP compressor and pump. Limited details of process conditions in the intermediate stages are given, but it is said that the final HP compressor lifts the pressure from about 40 bars to 145 whilst the CO₂ injection pump increases the pressure further to 240 bars.

The external CO₂ supply is assumed to be introduced from a ship via a buoy and delivered at the EOR module at 10 bars and 4°C.

5.2.3 Energy Institute assessment

EI (Energy Institute; 2013) has also made an assessment of the implications of treating a well stream from a CO₂ flooded oil reservoir, emphasizing the complexity and costs for retrofitting existing facilities. Hence, they are proposing various options for the treatment. The options include a complete treatment process including recovery of hydrocarbon gases (option 1) and a simpler version, involving only liquids separation and reinjection of the complete gas phase (option 2). The options are illustrated in the same Figure 5.3 below.

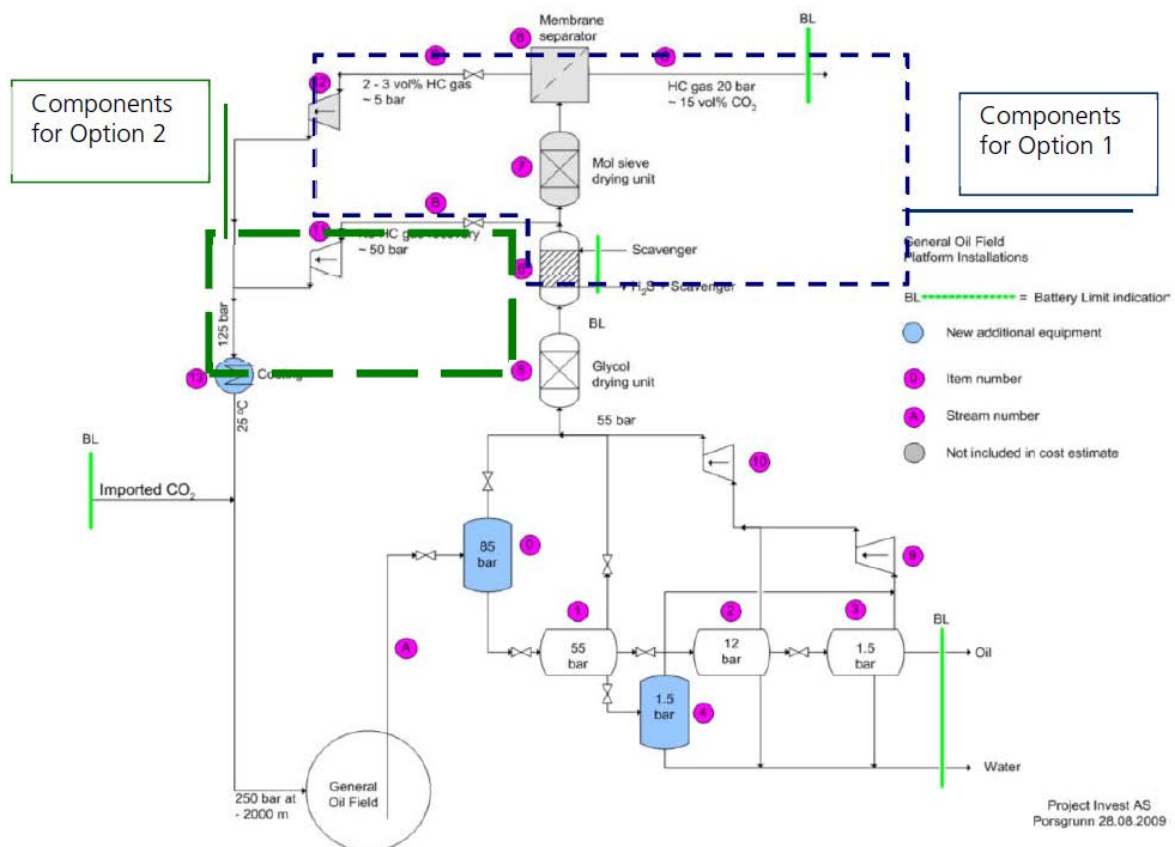

Figure 5.3. A proposed schematic of two various options for topsides treatment of well stream from a CO₂ flood from EI (2013), reprinted with permission from the Energy Institutes.

The well stream composition is not mentioned, but is assumed to be comparable to well stream data as given in the sections above.

From the flow diagram, it can be seen that a new HP separator (component 0) is introduced to the general arrangement in addition to LP CO₂/water separator (component 4).

The blue dashed line indicates the battery limit for new components for option 1, which comprises a solution for recovery of hydrocarbon gases. Accordingly, option 1 does not include stream B (routing of outlet from H₂S scavenger to HP compressor and HP compressor (component 11)). The need for a mole sieve (component 7) upstream the membrane is not explained. The recovered HC gas is exported with CO₂ content in the range 15 volume-%. The permeate gas, or CO₂ rich stream leaves the membrane separation at low pressure and with a HC gas content in the range 2 – 3%. It is likely that two separation stages are needed to reach this quality, but this is not mentioned. A compressor with high compression ratio is needed to increase the pressure for this stream to 125 bars as indicated. It is stated that the membrane separator could be replaced by an amine system.

Option 2, marked by the green dashed line, involves recycling of all the HC gas components including the CO₂.

5.2.4 Studies on the Norwegian Continental Shelf (NCS)

Aker Solutions have previously done several studies related to CO₂-EOR concepts in the North Sea. Some of these studies are classified as confidential and cannot be referred to in great detail in this report, but some general aspects can be mentioned. Two main studies referred to are (masked names and details):

- NCSA
- NCSB

The concepts of these studies vary quite much. The NCSA project is based on capturing CO₂ from an onshore power plant and to pump the gas in a pipeline to the offshore facilities. The gas would be further pumped into the various injectors from the offshore satellites. The main modifications to the facilities were limited to injection arrangements for the gas pumps and injection manifolds. The removal of CO₂ is planned to take place at an onshore power plant, so no treatment facilities have been included in this scope. The CO₂ being degassed from the various separation stages poses a significant increase in gas load on the equipment. The equipment is said to have sufficient capacity to handle the increased gas rates, but will require replacement of steel/cladding to withstand the corrosive nature of the gas. A major issue will be the handling and use of the CO₂ rich gas from degassing steps. Calculations show that the CO₂ content eventually would become higher than the flammable level and hence cold flaring is needed. The handling of the CO₂ rich gas streams in topsides facilities for such CO₂-EOR projects are mentioned in other papers as well as a critical issue that must be studied in more detail.

The NCSB was based on a concept to capture CO₂ on an onshore power plant and to use the gas for flooding the reservoirs in question. Various cases were specified for treating the gas at two offshore facilities.

The most comprehensive scenario was based on a gas treatment system that would leave the export gas with a CO₂ content of 10 mole-%. The interfaces with existing logistics and new building blocks are shown in Figure 5.4 and the modifications needed for this concept are illustrated in Figure 5.5.

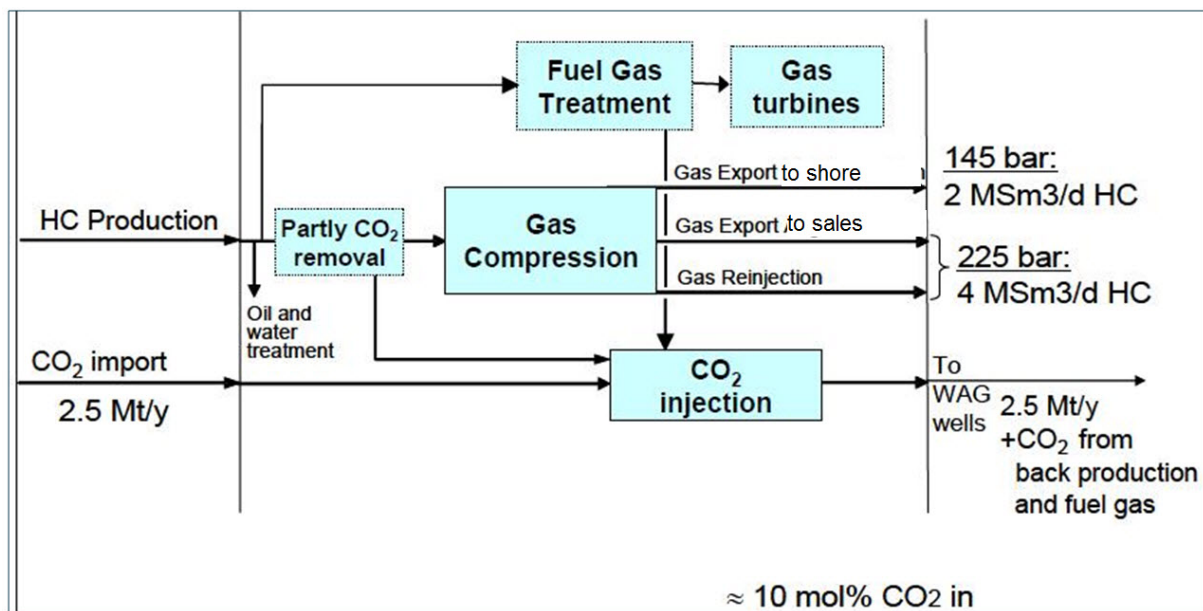

Figure 5.4. Interfaces between existing infrastructure and new building blocks (Courtesy Aker Solutions).

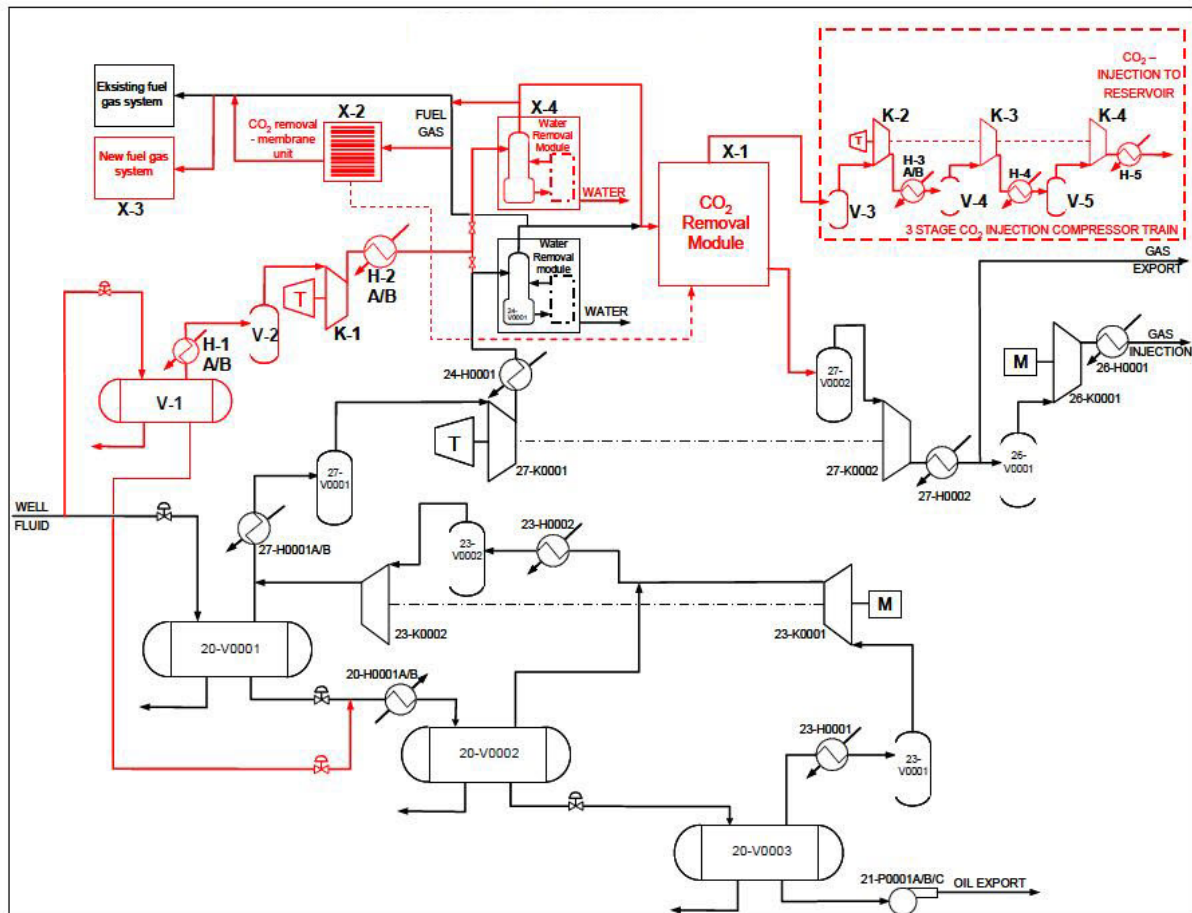

Figure 5.5. Flow diagram showing modifications to and new equipment for the case C4. (Courtesy Aker Solutions)

Figure 5.5 shows the need for new equipment (marked in red) to meet the design basis of the export gas quality to allow max 10 mole-% CO₂. The discharge pressure of the enriched CO₂ gas shall be 200 barg at the topsides. No specification to CO₂ purity in the CO₂ enriched gas is provided. It is mentioned that a gas cooling and pumping system can replace the last stage compressor (K-4) to obtain the advantage of transforming the 65 bar CO₂ (at the outlet of K-3) to dense phase and gain the corresponding liquid head in the injection system.

Some major topics to the selected process arrangement are:

- CO₂ flashing from dissolved gas in water.
- Impact on flare system by gas with high CO₂ concentrations.
- Type of CO₂ removal process (Module X-1).

For the gas treatment options, both amine-based and membrane separation systems were evaluated. For amine processes, the system based on a physical solvent (MORPHYSORB) was preferred over a conventional activated amine system. Further, the physical amine system was chosen as the base case CO₂ removal system over the membrane system. This was despite the considerable size and weight difference favouring the membrane system. The reason for the process selection was due to the considerable more detailed in-house knowledge about the amine system compared to the membrane; however, the membrane system is referred to as a promising alternative separation method.

5.3 Subsea solutions

Subsurface studies need to be carried out to determine the range of the design parameters for a separation system. Depending on the injection strategy, such as pure CO₂ injection, CO₂ Water-Alternating-Gas (CO₂ WAG), or CO₂ Simultaneous-Water-And-Gas (CO₂ SWAG), different incremental oil volumes are produced and production well effluents can vary considerably (Karimaie et al., 2016).

A subsea well treatment system could provide an attractive basis for economically feasible offshore CO₂-EOR gas separation system. Such concepts would represent a feasible solution for increased offshore oil production in combination with CO₂ sequestration as considerable CO₂ volumes are required in a typical offshore CO₂-EOR project. The critical system elements are:

- Reservoir management of injection strategy seems to have first order effect on economy of the whole concept.
- Robust compressor design to handle wide range of design parameters with minimum maintenance.
- Retrievable system components for inspection and maintenance.
- Production-well design modifications to handle flow assurance problems associated with CO₂ injection with minimum maintenance.
- Possibility to redirect production from the wells that experience unexpected CO₂ breakthrough.

5.3.1 Subsea CO₂ processing

In the literature, subsea technology for offshore CO₂-EOR deployment has rarely been described.

A recent study by Eggen and Nøkleby (2015) indicates that a concept for subsea processing of the well stream resulting from a CO₂ flooded oil reservoir could represent an attractive alternative compared to the topsides processing concept.

A subsea separation system would be designed to ensure that the oil and gas received at the existing processing facilities contains a limited amount of CO₂, reducing or removing the need for retrofitting for a corrosive environment. A subsea concept would also reduce the need for space and weight topsides, although space for some utilities will be needed (supply of power, MEG/methanol, etc.) unless they are supplied from shore or another facility.

Subsea systems are modularized to enable easier installation and retrieval operations. Size and weight of modules is a key parameter depending on the available vessels planned to be used for installation and retrieval operations. Compact equipment is preferred to minimize module size and weight in order to open up for more flexibility with regard to vessel selection. Several subsea processing projects have been installed and are in operation for various applications. No systems have yet been installed for subsea CO₂ handling.

A processing concept for CO₂-EOR will depend on the specific requirements for each field and facility. The main functions for a proposed CO₂-EOR processing concept are illustrated in Figure 5.6. Liquid and gas is separated, the liquid is taken into an oil/water separator and the water is re-injected to the reservoir. To achieve the required water quality for reinjection the oil stream will still contain a considerable amount of water, but the removal of water will free significant capacity in the produced water treatment system on the existing facility. Facilities operating in late life often have bottlenecks in the produced water treatment system. Additional steps can be introduced if needed, e.g., further degassing of the oil/water stream at lower pressure to remove more CO₂.

The gas is directed to a separator, separating the CO₂ from HC gas before the CO₂ is compressed and re-injected. Depending on the gas compression requirements more than one stage may be needed. In such cases interstage cooling and demisting may be required. Cooling at the compressor discharge may be used to get the CO₂ into dense phase. The HC gas with the remaining CO₂ is sent to the processing facility.

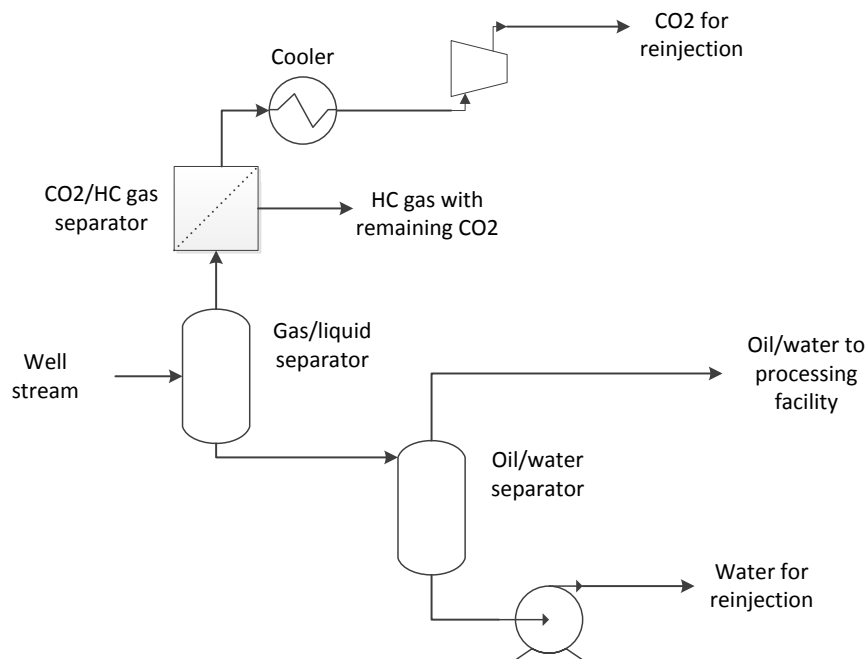

Figure 5.6. Main functions of a typical processing concept for CO₂-EOR. (Courtesy Aker Solutions)

There is high number of potential configurations for CO₂-EOR processing. Alternative concepts include compressing the mixed CO₂ and HC gas before separation. Additional processing steps may be added to improve the separation, but a subsea solution should be designed to be robust and reliable.

There have been several subsea processing projects installed in the last decade. Although technology qualification will be required for a subsea CO₂ processing system, several elements can be considered partially or fully qualified. Material selection for equipment will need to be reviewed for CO₂ processing applications.

The core technology for gas separation of CO₂ and HC gas must be qualified for subsea use. Membranes as described in the next chapter may be a well suited technology for subsea applications.

Available subsea processing building blocks:

- **Gas/liquid separators:** Several gas/liquid separators have been installed subsea including scrubbers. For a CO₂ processing concept, new and available compact options should be evaluated. These options include a compact cyclonic gas liquid separator like the GLCC or similar. The GLCC is the result of a JIP led by the University of Tulsa. Some qualification will be needed, but there is a lot of test data available through the JIP.
- **Liquid/liquid separators and de-oiling equipment:** De-oiling hydro cyclones have been qualified for subsea use. Cyclonic bulk de-oilers would likely require no or limited qualification.
- **Coolers:** Passive subsea coolers are qualified and installed as part of Statoil's Åsgard subsea compression project (no temperature control). Active coolers with temperature control will need further qualification to verify the relevant heat transfer coefficient to apply to the design in active mode.

- **Compressor:** A subsea compressor system for HC gas is qualified, installed, and in operation as part of the Åsgard subsea compression project. A tandem compressor for HC gas is under development as part of the same project. The tandem compressor is two compressors connected to one motor, enabling a higher compression ratio if run in a serial configuration. Further qualification verifications will be needed in order for the tandem compressor to be fit for CO₂ application.
- **Pumps:** Multiphase and single phase pumps are qualified technology for subsea use. However, the needed duty and impeller/diffuser selection are limited and would need to be evaluated from case to case.
- **Subsea de-sanding equipment:** Cyclonic de-sanders are considered qualified technology for subsea use.
- **Control system:** The control system in general is available for subsea use. However, a technology assessment for the exact configuration and instrument selection should be performed.
- **Power system:** Several power system solutions have been qualified for subsea use and are available.

5.4 Novel technology enabling CO₂-EOR

From the descriptions in the sections above, it is seen as mandatory that considerably more compact separation methods are qualified for more favourable concepts for offshore CO₂-EOR. This will provide substantially less impact on existing offshore facilities and enable subsea solutions.

5.4.1 CO₂ separation

In this chapter known and emerging technologies for separating CO₂ from other gas is described.

CO₂ separation with sorbents

Absorption denotes a process where a molecule or atom is dissolved in or permeates the bulk phase of a gas, liquid, or solid material. Adsorption, on the other hand, is the adhesion of molecules to a surface. This can be either a physical or chemical process. For CO₂ separation sorbents can be in liquid or solid states. The sorbent can be regenerated and reused, typically by changing the temperature or pressure.

The most widely used process for CO₂ separation and capture from acid gas containing streams is the chemical absorption process utilizing liquid amine solutions. Aqueous solution of monoethanolamine (MEA) or diethanolamine (DEA) is commonly used in the wet chemical absorption and low-pressure stripping of CO₂. In this process, the CO₂ reacts with the liquid amine solution to form a carbamate species. Upon heating, the carbamate species decomposes to release the absorbed CO₂ and regenerate the amine solution. The amine process is in use offshore at Sleipner. This process is not currently considered adaptable for application in a subsea environment due to complexity.

A novel amine adduct (Ayasse et al., 2016) has been synthesized providing a thin layer of cross-linked imine/polyol inside the pores of highly-porous silica particles. A packed bed of adduct is very active for absorbing acid gases, such as CO₂ and H₂S, from gas streams. The saturated bed can be stripped of acid gases at 90-130°C and at a pressure substantially above the absorption pressure using only a dry gas. For natural gas above 1070 psi (~74 bar), the CO₂ is recovered directly as a liquid, eliminating CO₂ compression costs for CO₂ disposal and providing an economical alternative technology for commercializing high-pressure gas containing elevated levels of CO₂.

For adsorption processes the surface area is a key parameter. Typical materials are activated carbon, zeolites, silica and more recently material-organic frameworks (MOF). CO₂ adsorption and selectivity can be improved by chemical modification on the surface of solids material possessing high surface area as described in Yu et al. (2012).

Supersonic CO₂ separation

Supersonic expansion can be a viable strategy for capturing CO₂ from a well fluid gas phase with high pressure. The core technology is a Laval nozzle equipped with liquid separation in the throat of the nozzle. When temperature and pressure is reduced as fluid velocity is increased liquid will condense if operated within the fluid phase envelope. The Laval nozzle is used to accelerate a pressurised gas passing through it to a supersonic speed. The thermal energy is converted into kinetic energy of the flow, and the flow goes through a sonic point at the critical point where the nozzle cross section narrows to its minimum. At that point, the flow speed reaches the sound velocity. The cross section increases again after the critical point, and the gas is further accelerated to supersonic speeds. The principal is shown in Figure 5.7.

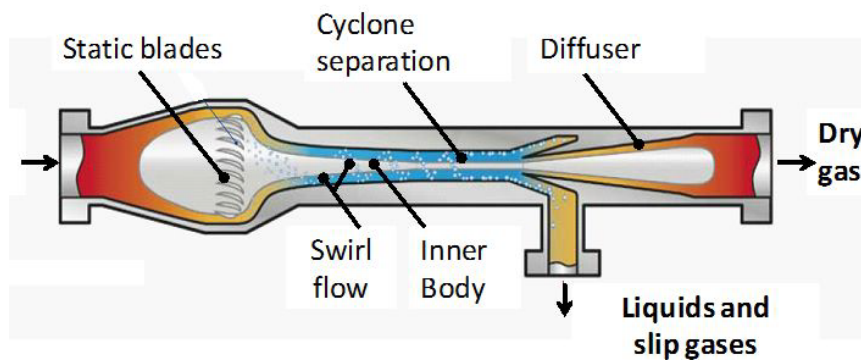

Figure 5.7. Supersonic nozzle with liquid separation. (From Netušil and Dítl, 2012, reproduced under the terms of the Creative Commons Attribution License (<http://creativecommons.org/licenses/by/3.0>), which permits unrestricted use, distribution, and reproduction in any medium, provided the original work is properly cited)

The expansion of natural gas makes it possible to cool the gas down to temperatures sufficient for condensation. Liquid separation is achieved by centrifugal force field is created by flow swirling in the chamber of the supersonic nozzle.

A typical process concept (Imaev et al., 2014) utilizing the 3S separator is shown in Figure 5.8. Necessary pre-treatment to get dry gas is not shown in the figure. Dry inlet gas, containing large amounts of CO₂, is cooled in a heat-exchanger, and after the preliminary expansion, it is fed to a rectification column. In the rectification column, a fractionating of inlet mixture occurs. Condensate, generally containing liquid CO₂, is sampled in the bottom of the column; condensate, containing ethane, methane, and CO₂, is sampled at the top of the column. Gas from the column is delivered to the inlet of the 3S-separator, to be cooled in the supersonic nozzle, and the carbon dioxide remaining in gas, is condensed.

Two-phase flow is directed from 3S separator to the conventional gas-liquid separator. Separated liquid, containing CO₂, is pumped to the column as a reflux liquid. HC gas from the separator is mixed with processed HC gas from a 3S-separator, cooled in the heat-exchangers block, and finally fed to consumers. Condensate from the bottom of the column is throttled, heated in heat-exchangers block, and directed to the compressor for injection.

combustion and produces exhaust consisting primarily of CO₂ and H₂O. Since the nitrogen component of air is not heated, fuel consumption is reduced, and higher flame temperatures are possible⁸.

The oxy-fuel combustion process will normally require a high degree of exhaust gas recirculation to lower and control the combustion flame temperature. Hence, by reducing the recirculation, the process can tolerate high amounts of CO₂ and other contaminants in the feed gas. This feature makes this solution especially well-suited for:

- Enhanced gas recovery (EGR) and EOR – it can take all the back-produced CO₂ in with the feed gas thus eliminating the need for additional CO₂ separation.
- CO₂ rich gas fields – it could enable economic developments by producing electricity.

The output of the liquid CO₂ and water can be injected for permanent storage or utilized for enhanced gas recovery (EGR) or EOR before being permanently stored.

The unit can be applied to provide local green power to offshore installations (individually or regionally) and thus replacing topside power generation that currently accounts for significant CO₂ emissions. Any excess power could be sold to the grid onshore for added value.

TriGen Energy has developed this technology for onshore and topsides use. Aker Solutions is developing a technology suitable for subsea use, Figure 5.9.

The subsea solution being developed operates at a high process design pressure, which enables direct liquefaction of the flue gas with moderate cooling. The liquefied exhaust gas (CO₂ and water) can then be pumped directly into geological formations for utility or storage with no costly post processing required, which makes this a cost-effective alternative for zero emission power generation.

By locating the unit subsea, close to production and injection wells, and with ample access to 4°C seawater, the following benefits are achieved:

- The robust oxy-fuel combustion process eliminates the need for pre-processing of the feed gas.
- The high pressure, naturally provided at the wellhead, combined with the necessary cooling provided by the cold sea water, eliminates the need for costly post-processing of the flue gas for re-injection.
- The short distances to production and injection wells save much on costly piping infrastructure.

⁸ https://en.wikipedia.org/wiki/Oxy-fuel_combustion_process

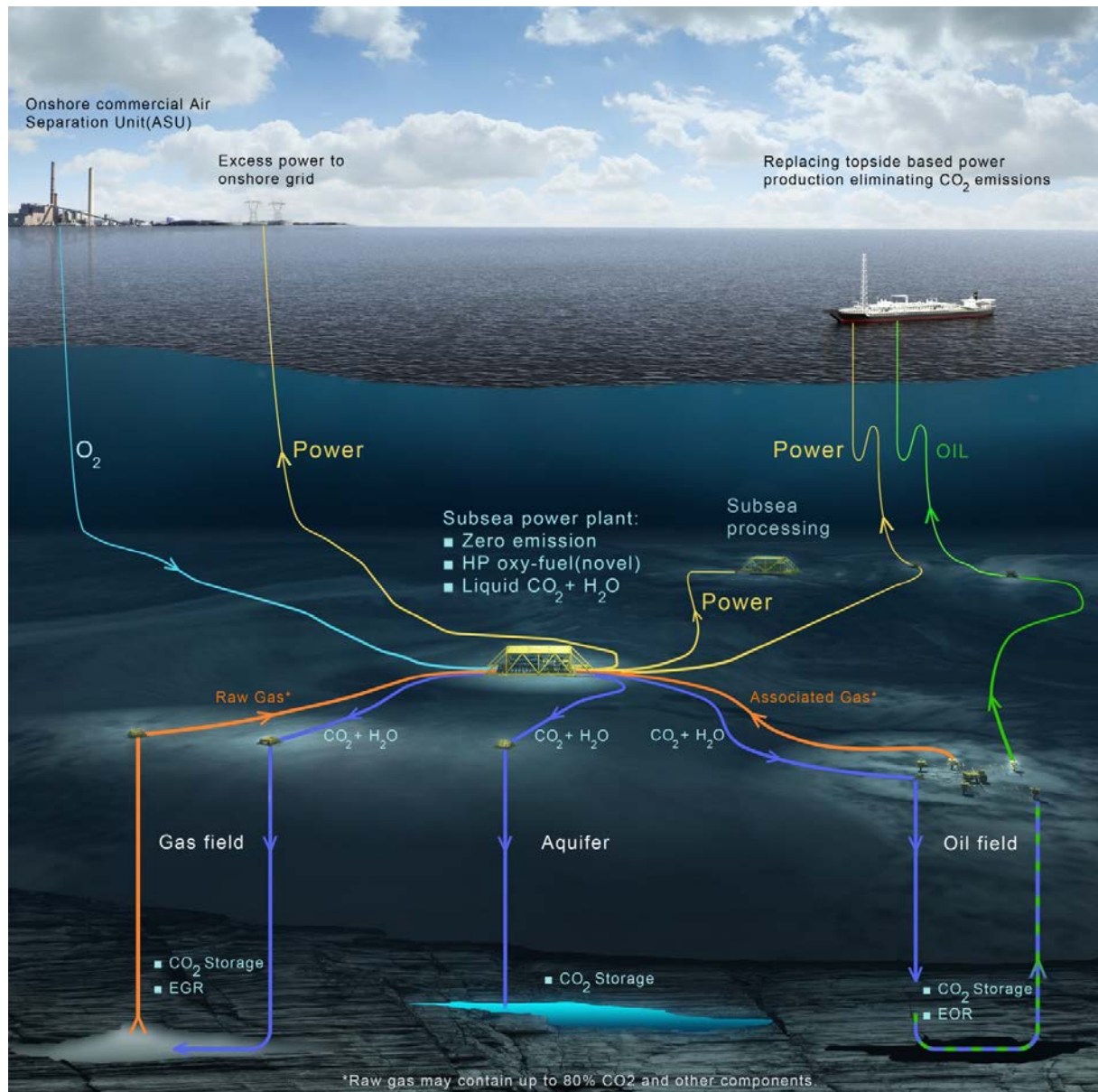

Figure 5.9. Illustration of subsea zero emission offshore power generation concept (Courtesy Aker Solutions)

5.5 Novel well technology

5.5.1 SWAG – Water Above Gas

Recently there has been an increasing interest in simultaneous water-alternating-gas (SWAG) in oil recovery operations using CO₂ as the lesser dense phase. This method involves the simultaneous injection of water at the top of the reservoir formation and injecting CO₂ at the bottom of the formation.

An injection technique in which gas and water are injected into reservoirs simultaneously can be beneficial. Gas is injected at the bottom of reservoir while water is being injected at the top. This technique makes advantages of the difference in water and gas densities to increase the hydrocarbon recovery. In primary recovery methods, oil is displaced toward production wells by the natural reservoir energy. Sources of natural reservoir energy are fluid and rock expansion, solution gas drive, gravity drainage, and the influx of water from saline aquifers.

The difference in water and CO₂ densities will provide a sweeping mechanism in which water tends to sweep hydrocarbons downward and the gas tends to sweep the hydrocarbons upward. It is expected that the two displacement mechanisms will work on establishing a flood front, which will increase the sweep efficiency and thus the oil recovery.

In order to achieve actual SWAG with water and gas being injected at different elevations in the reservoir through single well, separate flow conduits will be required for the two phases. This can be achieved either through a dual completion solution, or by utilizing the annulus for injection of water. A dual completion will have serious flow limitation due to the available space for two tubings within the space of a casing.

Using a single well for the combined injection of both water and CO₂ is now made possible with qualification of increased size of flow path through the X-mas tree via the crossover connection to the annulus side of the X-mas tree. Injection of water through the annulus utilizes the existing flow conduit that is the annulus, without impacting the size of the injection tubing. A possible implementation is shown in Figure 5.10.

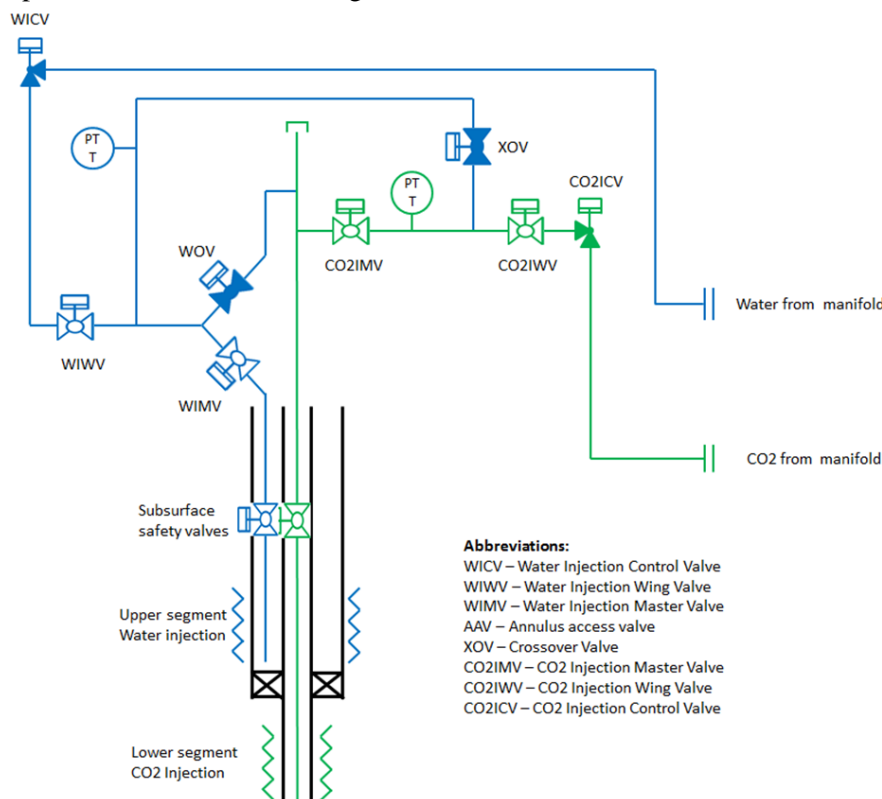

Figure 5.10. XMT and downhole schematic, SWAG water injection through annulus. (Courtesy Aker Solutions)

The well will, however, have to be recompleted in order to perforate at a suitable location and install an annulus isolation valve. Since the annulus is typically not used to transport significant amounts of fluids, the annulus access through a typical XMT is limited in size, and a special XMT will be required in order to achieve the desired water flow rates.

Normally, gas for artificial lift is injected on the annulus side of the X-mas tree through a two inch flow path. The EnQuest Kraken development in the UK sector of the North Sea utilizes the annulus to transport power fluid to a downhole hydraulic submersible pump. This has required a modified tree design to make possible transport of much higher rate of a denser fluid to the annulus side of the X-

mas tree. A five-inch flow conduit through the annulus side has been qualified for the supply of high rate of water as power fluid to the downhole hydraulic pump.

SWAG with water injection through the annulus could possibly pose challenges related to corrosion and integrity monitoring, however, given the relatively short duration of a CO₂ flooding phase these topics will be less critical than for a conventional injection well.

5.5.2 WAG – alternating water gas injection

A subsea CO₂ processing station located near to the production and injection area can facilitate comingling of produced water and CO₂ for injection into a single well.

A WAG (Water Alternating Gas) injection system utilised one well for injection of water for a duration of time follow by gas injection for another duration of time. When water and gas are supplied from topsides the fluid is cold when arrived to a subsea well and hydrate formation will occur if hydrocarbon gas or CO₂ is mixed with water. A subsea WAG system would therefore require purging with a neutral fluid when shifting medium to be injected. A fluid such as MEG or methanol at high pressure would be required as a barrier fluid between the supply of water and gas such that any leakage across a valve is from the barrier fluid to the water or gas.

The produced well fluid with CO₂ and water has natural high temperature which makes comingling of CO₂ and water and combined fluid injection into a subterranean reservoir possible when production and injection is physically near.

5.6 Mobility Control for CO₂-EOR

CO₂ mobility control is a very important issue in offshore CO₂-EOR projects. Due to large well spacing in offshore situation, injection sweep efficiency should increase considerably compared to onshore applications. If CO₂ is allowed to segregate inside the reservoir, substantial parts of the reservoir would remain un-swept reducing the volume of incremental oil significantly.

While common techniques such as CO₂ WAG or SWAG can still be used, studies have been carried out to develop new generation injection techniques to increase oil production beyond the conventional CO₂ injection and, at the same time, eliminating problems related to water injections such as water-shielding (Nazarian et al., 2014).

These techniques make use of increased miscibility of oil and injected CO₂ at lower temperatures by conditioning the reservoir temperature around the injection well and in the path between injectors and producers. Modification of injection composition is another method suggested to achieve control over CO₂ front. Composition of the injected mixture is modified at cycles to create gas-like and liquid-like behaviour at injections point. This resembles a WAG injection but unwanted effects such as relative permeability hysteresis are avoided.

The simulation studies indicate that these methods can be more affordable and effective than traditional methods such as CO₂ WAG or carbonated water injection in situations where pressure build up can be an issue (CCS), water resources are scarce, or water shielding is cause of concern during CO₂-EOR floods in water-wet reservoirs. These methods work by reducing the magnitude of gravitational forces through an increase in the density and viscosity of the injected phase. For CO₂-EOR, in addition to property modifications, compositional effects (i.e., component exchange between the injected blend and in-situ hydrocarbon) also play an important role.

For CO₂-EOR, the costs associated with injection of modified mixtures of CO₂ are more affordable and economy of the project is more manageable. For a properly designed injection, it is possible to produce back the injected hydrocarbons that are used to make up the CO₂ mixture blend.

The CO₂ storage capacity is strongly limited by the unstable displacement of water and oil since CO₂ at reservoir conditions is very mobile and has very low viscosity. These conditions cause early CO₂ breakthrough. Viscous fingering, gravity override and flow in high permeability pathways reduce the volumetric sweep and the effectiveness of CO₂ injection processes. Foam is a potential remedy for this problem. Application of foam, by adding surfactants to the CO₂, can give CO₂ a more favourable mobility ratio relative to oil and water. This will improve oil recovery and the net CO₂ storage potential; as also mobile water will be displaced, providing more storage volume for CO₂. This reduces needs for handling and re-injection of produced CO₂. Thus, CO₂-foam EOR reduces operational cost, increases the commercial value of CO₂, and provides improved oil production revenue for the industry and enables CCUS.

The microscopic sweep during CO₂ injection is potentially very high as result of miscibility between oil and CO₂, diffusion, and oil swelling. The volumetric sweep efficiency, however, is generally low because of the high CO₂ mobility and low density. This causes fingering, gravity segregation, and early breakthrough in the production well, resulting in the need to recycle large quantities of CO₂. This is especially challenging in fractured reservoirs, defined here as dual porosity systems with bulk oil located in low permeability matrix surrounded by a high permeable fracture network, where the contribution from viscous forces is limited. Here, the main production mechanism is gravity drainage, with the additional benefit of diffusion and volume expansion of oil, especially near or at miscible conditions (van Golf-Racht, 1982). Laboratory experiments indicate that miscible displacement/drainage aided by diffusion in fractured reservoirs can be an efficient production mechanism (Firoozabadi, 1994), however, it requires close fracture spacing for the rate of diffusion to significantly contribute to oil recovery (Firoozabadi, 1994; Thompson and Mungan, 1969; Trivedi and Babadagli, 2008). In most fractured reservoirs gas-oil gravity drainage is a slow process, with early breakthrough of injected gas and poor CO₂ utilization (see e.g.: (Grigg and Schechter, 1997; Jonas et al., 1990).

The poor macroscopic sweep efficiency associated with the large mobility of the injected CO₂ may be improved with CO₂-foam to produce a more favourable mobility ratio to increase sweep, and thereby improve oil recovery (Talebian et al., 2013). Foam effectively increases the viscosity of the gas phase by mixing gas and surfactant solution, creating a discontinuous gas phase separated by thin water films (lamella) stabilized by the surfactant. While there have been several successful foam pilots (see e.g.: (Blaker et al., 2002; Li et al., 2009; Mukherjee et al., 2014; Sanders et al., 2012; Yu et al., 2008), historically very few foam pilots in fractured reservoirs have been performed, and those few have largely been deemed unsuccessful (Enick et al., 2012; Smith, 1988). This has been attributed to the lack of foam generation mechanisms in fractures, namely snap-off, film division and leave-behind. Recent research, however, confirms in-situ foam generation in single fractures (Buchgraber et al., 2012; Kovscek et al., 1995), leading to increased sweep (Yan et al., 2006) and flow diversion within a rough-walled carbonate fracture network during co-injection of surfactant and gas (Fernø et al., 2014). Hence, the reported unsuccessful foam pilots in fractured reservoirs may be related to operational issues or lack of optimized, field-specific surfactants (Castanier and Hanssen, 1995; Prieditis and Paulett, 1992), rather than lack of foam generation mechanisms in fractured reservoirs. With the development of better surfactants (Buchanan, 1998; Cui et al., 2014; Elhag et al., 2014; Ryoo et al., 2003), the injection of foam in naturally fractured reservoirs is increasingly recognized as a potential EOR technique in fractured reservoirs (Farajzadeh et al., 2012; Haugen et al., 2012; Lopera Castro et al., 2009; Panahi, 2004; Pancharoen et al., 2012; Zuta and Fjelde, 2010). For a comprehensive literature review of CO₂ mobility control, including foam, please see (Enick et al., 2012).

CO₂ foam injection can be an important tertiary oil recovery process for mature water flooded fields worldwide. Norway has e.g., more than 23 mature water flooded reservoirs of significant size that after water flooding will have approximately 2,400 million Sm³ residual oil (Grimstad et al. 2012). According to a 2010 US White Paper on CO₂ EOR (DOE/NETL-2010/1417, April 2010, ARC 2010), US import of foreign oil may be reduced by 30% if a "next generation CO₂ EOR technology" based on

mobility control can be achieved, providing 137 billion barrels of additional oil from on-shore oil fields in the US. A successful tertiary CO₂ EOR project provides synergy between the need for increased energy production and the reduction in emission of anthropogenic CO₂ by storage in sedimentary rocks.

There is a need for new knowledge and improved tools to design and predict foam flooding as mobility control and improved sweep in secondary and tertiary EOR in laboratory testing, field pilots, and optimize full field implementation. Field specific properties such as oil composition, brine salinity, temperature and pressure, and reservoir lithology will require carefully adapted surfactant formulation for each case. A roadmap to successful field implementation using foams for mobility control needs to be developed and tested in onshore *field pilots*, in both clastic and carbonate reservoirs, before offshore operations are launched. Low cost, high stability, and environmentally acceptable surfactants for CO₂ foam EOR field implementation needs to be developed and this is most cost efficient in onshore operations.

Recent research has developed formulations for CO₂ foam mobility control in both sandstone and carbonate formations (*cf. US DOE projects DE-FE0005902 and DE-FE0006823*). An important finding of this research is that one formulation does not fit all reservoirs. A distinction must be made between sandstone and carbonate/chalk lithologies due to different adsorption characteristics. Anionic surfactants are preferred for sandstones as the anionic surfactants are repelled by the negatively charged sites of the grain surfaces. In high temperature, high salinity, carbonate formations have required application of a switchable-cationic ethoxylated amine surfactant to form a highly viscous CO₂ foam (Cui et al., 2014; Elhag et al., 2014). In addition, CO₂-soluble surfactants may be injected with the CO₂ (Chen et al. 2012, McLendon et al. 2012) to assure that the surfactant goes where the CO₂ goes rather than only following the water. This can be useful both for EOR and saline aquifer storage.

Foam injection for gas mobility control and improved sweep efficiency in heterogeneous reservoirs has recently been targeted as a key research area for EOR (Haugen et al., 2012, Pancharoen et al., 2012, Bertin et al., 1999, Farajzadeh et al., 2012, Haugen et al., 2014, Fernø et al., 2014, Haugen et al., 2012, Brattekkås et al., 2013, Gauteplass et al., 2013, Eide et al., 2013, Fernø et al., 2012, Haugen et al., 2010, Ersland et al., 2010). Current fundamental knowledge of the physics of foam behavior in heterogeneous rocks is inadequate to satisfactorily describe and predict fluid flow and thus oil recovery. Existing models can describe foam behaviour in oil-free systems (Vassenden and Holt 2000). A general characteristic of many surfactant systems is that the foam is unstable in the presence of oil at even low saturations. It is unclear how residual oil after CO₂ flooding will affect foam stability in flooded regions of typical NCS oil reservoirs. Successful implementation of CO₂ Foam EOR requires that surfactant systems that generates foam and lowers mobility in the absence of oil, while selectively not foaming in the presence of residual oil and identify surfactant systems that form stable foam also in the presence of CO₂ residual oil. Thus, these surfactants may be used for selective mobility control in regions without oil or with CO₂ residual oil, while allowing CO₂ to flow efficiently and produce oil in regions where the oil saturation is higher. Direct observations on pore scale and *in-situ* imaging of foam propagation and oil saturation at core- and block scale at reservoir conditions have been reported in the literature and map the mechanisms involved.

The behaviour of foam for varying oil saturations is difficult to characterize and model. Research for improving the modelling of foam in heterogeneous systems with and without oil present is needed. A novel technique for CO₂ imaging has recently been reported, where, for the first time, medical Positron Emission Tomography (PET) explicitly depict CO₂ flow in porous rocks. A better fundamental understanding of CO₂ foam behaviour in sediments analogue to those found in reservoir formations will allow industry to better design processes for a number of fields.

Some important requirements for successful offshore CO₂ Foam EOR developments have been identified as follows:

- Complete value chain of operations needs to be included covering capture, transport, and storage.
- CO₂ needs to be captured near field site or transport infrastructure available.
- Synergy is needed with ongoing onshore CO₂ Foam EOR pilots in Texas, where 80% of all CO₂ EOR projects are performed:
 - Provides 30 years' experience in CO₂ EOR.
 - Cost associated with onshore field tests are only a fraction of the costs for offshore field tests, thus offshore technology development needs to be linked with onshore CO₂ Foam EOR innovations.
 - Short inter-well distances in onshore oil fields yield faster results and less expensive testing environment for offshore challenges.
- Foam and mobility control has significant potential for a “quantum leap” within EOR.
- International collaborations are needed, both because of high cost and complexity.
- Up-scaling is the major challenge in obtaining reliable predictive models of oil recovery in CCUS; this may be achieved by step-wise up-scaling from lab to onshore operations and finally to offshore pilots.
- CO₂ Foam EOR mobility control may establish next generation CO₂-EOR flooding providing potentially less than 10% residual oil in swept zones.

5.7 Conclusions

Significant and promising technologies for reducing the cost of separating CO₂ from production fluids in CO₂-EOR operations are under development and, to some degree, testing. Compact sub-sea equipment for CO₂ processing and mobility control using CO₂ foam appear to have large potential when it comes to reducing CAPEX and OPEX for CO₂-EOR projects.

6. CO₂ SUPPLY CHAIN ISSUES

Offshore CO₂-EOR with CO₂ sources onshore will require a certain degree of flexibility:

- In general, CO₂-EOR projects will have a shorter lifetime than the emitting sources, which will be power and industry plants.
- The amount of CO₂ available from one source may be too small to meet the demands of one or more CO₂-EOR projects.

Thus, an optimal solution for offshore CO₂-EOR may require an infrastructure, or network, that connects sources and CO₂-EOR fields. CO₂ infrastructure for offshore CO₂-EOR will generally consist of capture from sources, individually or in clusters, transport by pipeline or ship to a collection hub⁹ and distribution to the individual CO₂-EOR fields. This section will deal with the transport part and collection hub, including conditioning of the CO₂ and injection approaches.

Hubs are common in the natural gas distribution industry, both in North America and Europe. Here, pipeline networks interconnect in order to bring together gas from many different production fields, or to distribute gas to dispersed markets. Hubs for CO₂-EOR also exist onshore in the United States, in the CO₂ pipeline distribution industry. Two examples are the Denver City and McCamey Hubs (GCCSI, 2016a)¹⁰. Much of the CO₂ transported through the US pipeline system is used in EOR operations.

6.1 Considerations when choosing Transport Methods

As is discussed below, the technology for transportation is available and in use. This applies

⁹ Here a hub is a facility that collects captured CO₂ from several sources

¹⁰ GCCSI = Global CCS Institute

both to pipelines and ships, although the former is limited to one offshore CO₂ pipeline and the latter to small ships.

Offshore CO₂-EOR projects will be site and situation specific. Many considerations must be made when planning and designing infrastructure for offshore CO₂-EOR. Economics will be a main driver on the choice of CO₂ transport technology options. Factors to consider include (not necessarily in order of priority):

- Number of fields to be served.
- Demand and supply of CO₂ and capacity utilisation.
- Impacts of intermittent supply and injection of CO₂.
- Economy of scale .
- Location of fields relative to sources, i.e., distances for transport.
- Lifetime of EOR project and need for flexibility.
- Flexibility of transport method.
- Need for new wells (wells are not a topic for this chapter).
- Possibilities to re-use existing infrastructure, particularly pipelines.
- Reservoir requirements for CO₂ conditioning before injection with respect to e.g.:
 - Need for compression of the CO₂.
 - CO₂ quality and characteristics; acceptable combinations of pressure, temperature, and (maximum) flow rates ([p, T, q]) at the wellhead (avoid freezing, hydrate formation, and fracturing of the reservoir).
 - Need for additional processing of CO₂ rich gas to remove impurities.

The injection approach for CO₂ into the reservoir will depend on the transport method from source or hub to the injection well. The options include:

- Direct from the ship via buoy.
- Offloading to an offshore intermediate storage, floating or fixed.
- Offloading to onshore intermediate store and pipelines/ships to offshore CO₂-EOR fields.

6.2 Status and challenges - Pipelines

Pipelines are the most common method of transporting the large quantities of CO₂ involved in CCS projects. GCCSI (2015, 2016b) and ZEP (2017) give the status of CO₂ transport by pipeline, including international R&D activities. Since that publication, ISO has issued an international standard with focus on what is distinct to CO₂ pipelines relative to other pipelines (ISO, 2016). There is, however, very limited experience with CO₂ pipelines through heavily populated areas, and the 153km pipeline at Snøhvit is the only offshore CO₂ pipeline.

The technology for CO₂ pipelines is well established and CO₂ transportation infrastructure continues to be commissioned and built, but RD&D can still contribute to optimizing the systems, thereby increasing operational reliability and reducing costs (GCCSI, 2015). This applies, in particular, to understanding the impacts of impurities and validating predictive models for CO₂ pipeline design.

Where it is feasible, reuse of existing pipelines could be a very cost-effective transportation solution, although the viability of such pipelines to transport CO₂ may be uncertain. Examples of locations with existing pipeline networks are the Scottish and Norwegian sides of the North Sea as well as the US Gulf coast. The use of existing pipeline networks requires a suitable CO₂-EOR 'end field' to be located close to the offshore pipeline location. Planned supply chains for CO₂-EOR should perform inspection of existing lines with the objective to decide to what extent they can be reused, e.g.: with construction of new risers and 'J tubes' that will connect the pipelines to the 'end fields'. The workload associated with this could be an order-of-magnitude less than would be involved with a new pipeline, at least in the Scottish North Sea (Element Energy Limited, 2013).

Compression will most likely be needed if pipelines are re-used to transport CO₂. Alternatives include:

- Booster platform for re-use.
- Extra compression power on existing platform to be used for injection.
- Onshore compression.

Sub-sea compression near the well (see Ch. 4) has the potential to become a cost-efficient alternative to the above.

If new, purpose-built CO₂ pipelines are constructed they may be able to operate at sufficient pressure that re-compression at the field is not required before injection into the reservoir.

6.3 Status and challenges – Ship transport

Ship transport can be an alternative to pipelines where CO₂ from several medium-sized (near) coastal emissions sources need to be transported to a common injection site or to a collection hub for further transport in a trunk pipeline to offshore storage. Transport of food quality CO₂ by ships and barges already takes place on a small scale (1,000 – 2,000 m³) in Europe. The CO₂ is transported as a liquid at 15 – 18 bar and – 22 to –28°C but for larger volumes 6-8 bar and around –50°C may be better (Skagestad et al., 2014). Some design work has been started by major carriers, such as Mærsk Tankers (undated), Vermeulen (2011) and Chiyoda (2011, 2012). A feasibility study (MPE, 2016)¹¹ for implementation of a full-scale industrial CCS project in Norway concluded that ship transport is not a technical barrier for realization of the full-scale. This is in agreement with a major Dutch study (CATO, 2016), a Scottish literature study (Brownsort, 2015) and the Antony Veder study (Vermeulen, 2011). The studies considered ships in the range of 5 kt to 50 kt CO₂ capacity. The MPE study also included 45 bar and + 10°C in addition to the above two conditions.

Transporting CO₂ as a liquid in ships requires liquefaction facilities before loading. The technology for this exists. However, in the cases of low-medium pressures and temperatures the CO₂ will require conditioning before injection into the reservoir.

Offloading to onshore or floating intermediate storage sites will not require conditioning of CO₂ on the transport ship. The process equipment for compression, heat exchange, and injection will be located on or at the intermediate storage site, which would not be included in the transport interface, and is part of the storage sub-project. The transport ships will contain the necessary equipment (e.g.: pumps) to transfer the CO₂ to the intermediate storage site. There is little relevant experience from this type of offloading system for floating intermediate storage, whereas the technology is available for onshore intermediate storage.

In the case of direct injection from ship to well, it is anticipated that this will take place a buoy. Single point moorings and transfer technologies are available²⁷ but may need adapting for handling CO₂. In this case, conditioning, pressurisation and heating of the CO₂ will need to take place on the ship. This will require significant energy in the cases of low pressure, even if sea water is used as heat source. The extensive experience with offloading buoys in the North Sea does not cover the higher frequency connection and disconnection that would be needed for direct injection from transport ships. This issue is in need of further engineering for optimisation (Vermeulen, 2011; Brownsort, 2015). One consideration for this option is a possible requirement for CO₂-EOR of continuous or semi-continuous supply of CO₂, which may require a buffer storage not offered by direct injection from ships.

No major issues with ship transport, loading, and off-loading of the CO₂ have been revealed in the reviewed studies. However, as pointed out by Brownsort (2015) there is little coverage of offshore

¹¹ MPE = Norwegian Ministry for Petroleum and Energy

CO₂-EOR in the literature, it being included under general CO₂ storage. There may be requirements to the CO₂ supply chain specific to CO₂-EOR that have not been addressed or fully considered in the literature. Further needs for technology development of ship transport is linked to optimization and qualification of the first systems for large-scale projects.

Offshore loading/unloading operations on the Norwegian continental shelf are done either via tandem from the stern of a ship-shaped FPSO, or via a subsea flowline and loading/mooring buoy where the shuttle tanker can connect. Both technologies could be applicable in a CO₂ for EOR project, where injection could occur either directly from a shuttle tanker with onboard injection pumps, or via a dedicated storage and injection tanker.

In the latter case, the storage tanker would be permanently moored at the field, with sufficient storage capacity to allow continuous injection and injection pumps. Shuttle tankers would arrive at the field and offload to the storage and injection vessel, typically using a bow to stern loading system as indicated in Figure 6.1.

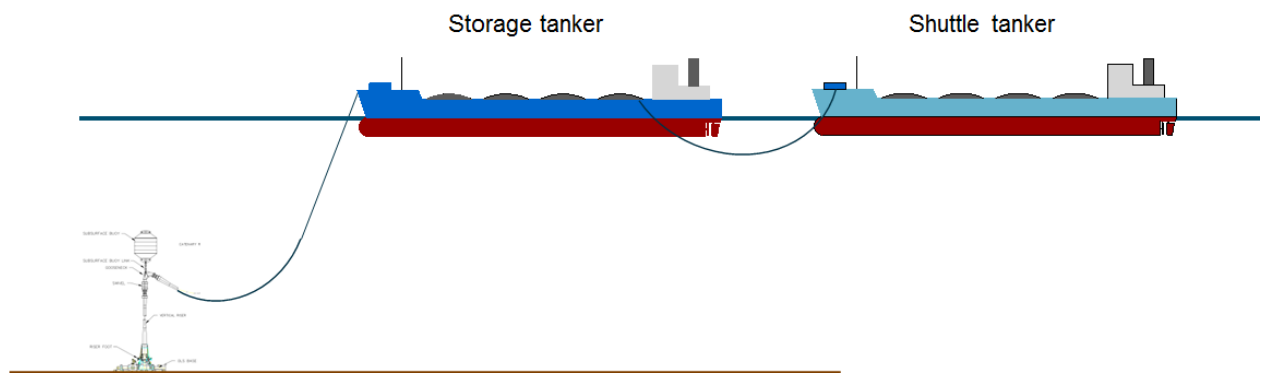

Figure 6.1. Bow to stern loading from shuttle tanker to storage and injection vessel. Possible buoy solution indicated. (Courtesy Aker Solutions)

In the case where injection occurs directly from the shuttle tanker, the shuttle tanker would arrive at the field and connect directly to the offloading buoy as shown in Figure 6.2.

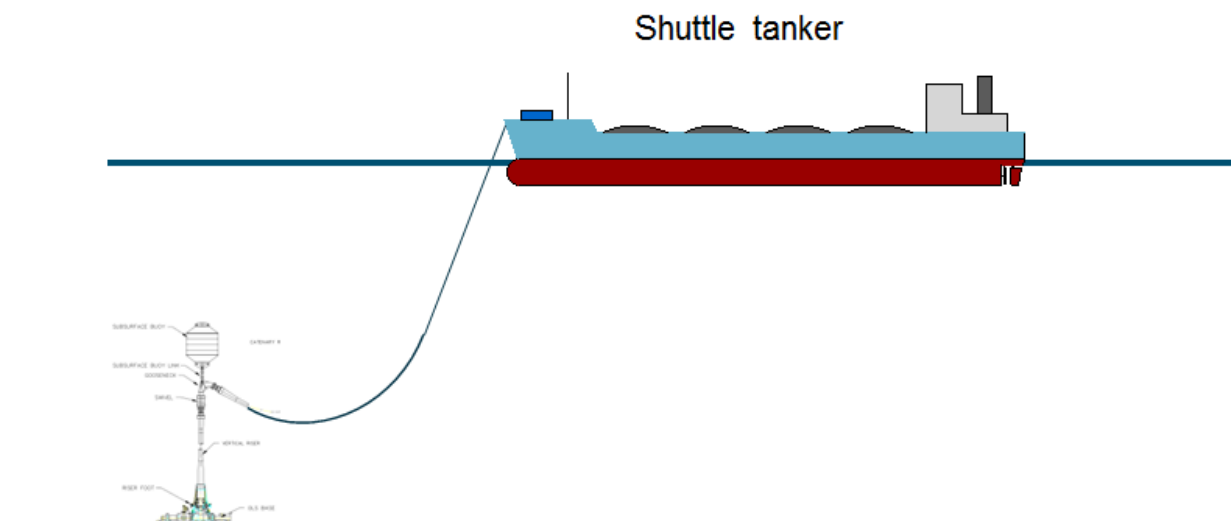

Figure 6.2 Shuttle tanker connecting directly to offloading buoy. (Courtesy Aker Solutions)

Although the loading and offloading systems described are well known and in use, further qualification may be needed. Parameters to be considered include a large number of load cycles at relatively challenging pressure and temperature conditions compared to a typical dead oil loading case and material requirements for handling CO₂.

6.4 Initiating new offshore transport systems

CO₂-EOR on a profitable scale will likely require a constant and stable supply of CO₂ over some decades and a flexible infrastructure system for transporting the CO₂ to several oil fields. For this to happen, different industries, sectors, and authorities will have to work together and coordinate activities. The activities will include CO₂ capture at regional clusters of power and industrial plants, transportation of the CO₂ to hubs and the individual receiving fields and injection. Preliminary studies of the feasibility of such systems have already started in some regions, most notably the Gulf of Mexico and the North Sea. As there are time windows for profitable opportunities oil and gas authorities should work with other parts of the governments and the industries to create business models and start coordinated planning immediately.

Most gaps, risks, and challenges connected to offshore CO₂-EOR are commercial and political in nature. Some thinking on business models have started that include the separation of CO₂ capture at the sources from the transport and storage parts (Esposito et al., 2011; MPE, 2016; Pöyry, Tesside Collective, 2017 and Banks et al., 2017). In these models a split of costs and risk between the government and the industry players have been explored, e.g.: that governments take a certain responsibility to develop transport and storage networks.

For a pilot project, one viable alternative could be to place suitable pressure vessels on the deck of an outdated shuttle tanker, which would be a low CAPEX alternative suitable for verification of injection concepts. However, as the market develops, there is no doubt that the availability of suitable vessels for CO₂ transport will improve. Still, it seems unavoidable that custom built vessels will be required for early commercial projects.

6.5 Case studies

There are presently no operating examples of networks or infrastructure where CO₂ is captured from more than one source, collected, and transported to an offshore oil field for CO₂-EOR. Below follow some examples of studies that have been undertaken.

6.5.1 UK case studies

In the UK several analyses have been conducted to investigate the potential for CO₂-EOR in oil fields in the UK sector of the North Sea (Reid, 2015, SCCS, 2015). It is envisaged that CO₂-EOR, if carefully navigated, can accelerate the emergence of a system for capturing and transporting CO₂ for storing beneath the sea bed, Figure 6.3. The potential for incremental oil production has been estimated to above 3,000 million barrels with an associated storage of more than 1,430 million tonnes of CO₂ for all fields on the UK continental shelf. The potential of fields in the Central North Sea (CNS), will be more than half of this. The fields in the CNS can possibly be served by some re-purposing of exiting offshore pipelines and the industrial infrastructure at St. Fergus.

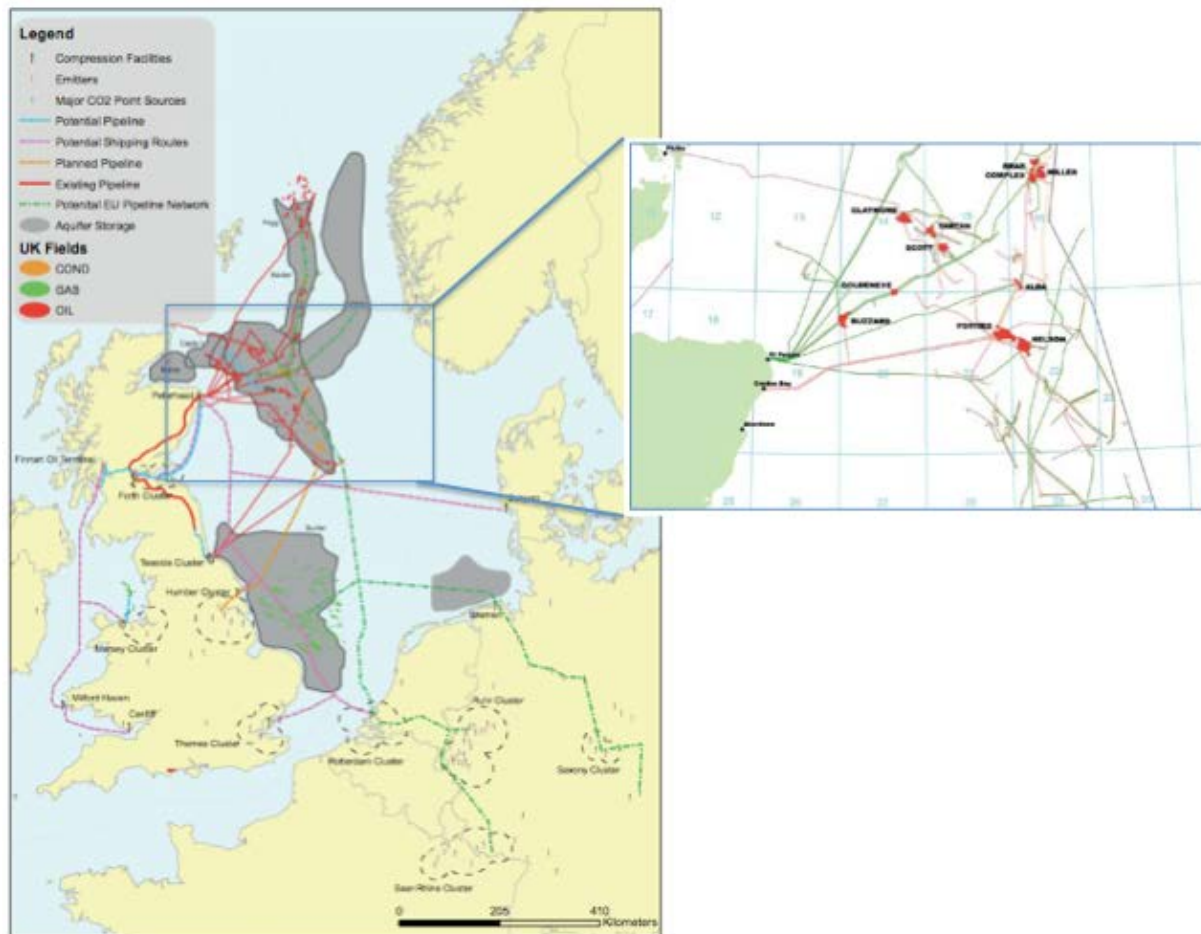

Figure 6.3. Conceptual vision of CO₂ storage beneath the North Sea, linked to emission sources with capture. Reproduced by permission of SCCS (2015). The insert (from A. Kemp, *Global Energy Systems Conference*, 2013) shows fields in the UK Central North Sea that have been found particularly suitable technically and economically for CO₂-EOR.

6.5.2 A Norwegian case – Gullfaks

In 2003-2004 Statoil undertook studies of CO₂-EOR for the Gullfaks Field (MPE, 2010; Berger, et al., 2004, Elsam et al., 2003). It was assumed that 5 Mt CO₂/year would be available for 10 years. This would give an increased oil production of 18.3 Sm³ relative to water injection, or 4.1% of oil in place. The concept was found to be technically feasible, but with the CO₂ prices and credits as well as oil price at that time the economics were unfavourable for CO₂-EOR.

Several options for CO₂ supply were evaluated. In none was a single geographical source sufficient for the needs of Gullfaks and scenarios with delivery of CO₂ from two or more sources were developed. The base case (5 MT CO₂/year) transported CO₂ by pipeline from two sources in Denmark to Gullfaks, with a trunk line from Gullfaks to the gas terminal at Kårstø for the back-produced CO₂ and a line from Kårstø to the trunk line for the recycled CO₂ (see Figure 6.4 for locations). Other scenarios included ship transport as well, an example is shown in Figure 5.3 for a supply of 5.5 MT CO₂/year.

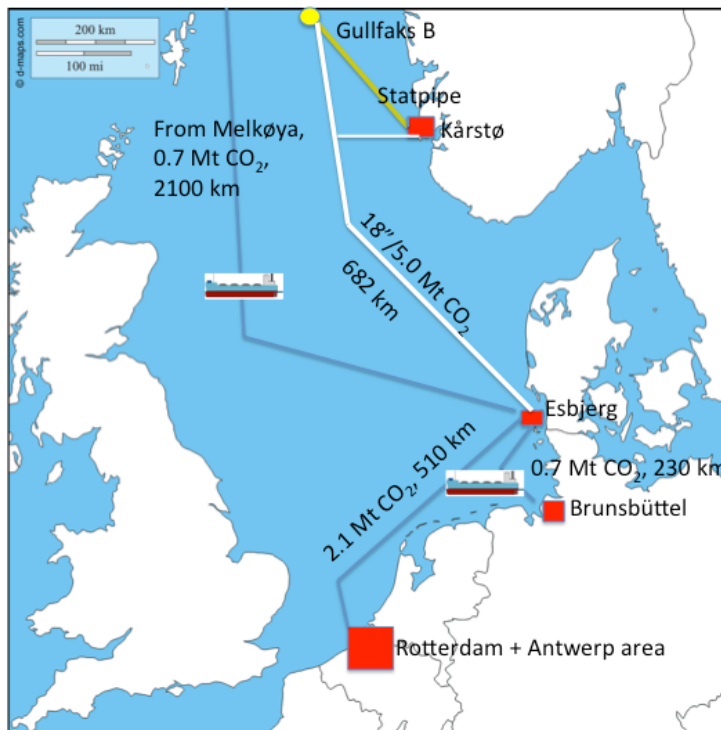

Figure 6.4. A network of sources and transportation means to supply Gullfaks with 5.5 MT CO₂/year. Schematic figure based on Agustsson and Grinestad (2005), Berger et al. (2004) and Elsam et al., 2003

6.5.3 A Vietnam case – Rang Dong Field

A joint Japan and Vietnam CO₂-EOR pilot test was conducted on the Rang Dong Field offshore Vietnam in 2011 as a single-well Huff 'n' Puff following a preliminary study that indicated feasibility (Uchiyama et al., 2012; Ha et al., 2013; Kawahara, 2016). CO₂ was injected into the well and the well was flowed after soaking. Operation was successfully completed without any operational trouble and HSE issues and the CO₂ Huff 'n' Puff Test provided following results:

- CO₂ Injectivity confirmed .
- Oil Production Increase .
- Water Cut Reduction.
- Oil Property Changes by CO₂ injection .
- Oil Saturation Changes before / after CO₂ injection.

However, the feasibility study involving possible CO₂ sources, a fertilizer plant and a CO₂-rich gas field, with transportation by pipelines (Figure 6.5), showed that the cost was detrimental to the project and it was terminated. The main cost drivers were the pipelines and modifications on the platform for separating and re-injecting recycled CO₂. EOR using hydrocarbon gas (HCG) has significantly better economy (US \$100 mill vs. US \$1 000 mill) despite lower EOR. The Japanese oil company JX concluded that CO₂-EOR is technically applicable, but economically challenging for Rang Dong due to inconveniently located offshore project, but that they will continue development of CO₂-EOR technology for maximizing oil production and reduction of CO₂.

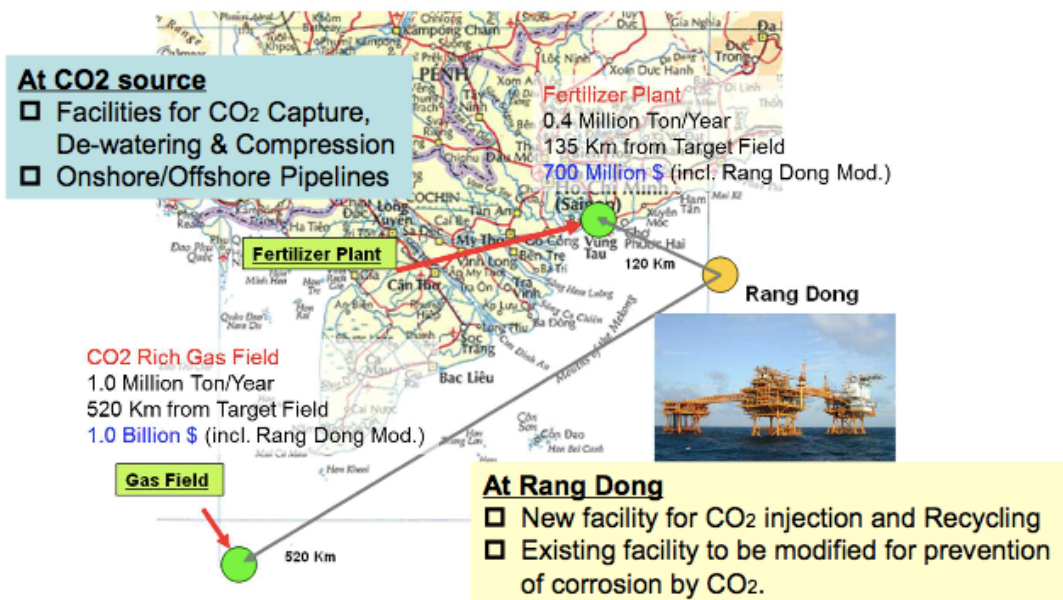

Figure 6.5. Location of the Rang Dong Field relative to the CO₂ sources. From (Kawahara and Hatakeyama, 2016)

6.6 Conclusions

There are no technical barriers to building CO₂ infrastructures that can supply CO₂ to offshore EOR projects, although there is some need for optimisation and some systems will need to be qualified for the specific use. Gaps, risks, and challenges are commercial and political in nature and may include the cooperation of different industries across the CCS value-chain, the lack of project-on-project confidence, the completion of projects on cost and schedule, operational availability, flexibility, reliability, financing and political aspects, and last but not least, lack of business models for larger CCS systems. Some thinking on business models have started that include the separation of CO₂ capture at the sources from the transport and storage parts (MPE, 2016; Pöyry and Tesside Collective, 2017).

7. MONITORING, VERIFICATION AND ACCOUNTING TOOLS FOR OFFSHORE CO₂-EOR

In this chapter we review available work and best practices relevant to setting the goals of monitoring, verification, and accounting (MVA) applied to an offshore EOR project, focusing on the activities in the geologic environment including wells. No specific and detailed precedent tailored to this topic is available. Extensive work on MVA activities is focused on the other subsets of geological environments, which include diverse onshore settings and saline aquifers and depleted fields offshore (Table 7.1). Selected general citations are provided background to the current topic in Table 7.2, however because of the abundant publication available, no detailed review of the many options and approaches to designing a monitoring program and selecting monitoring tools is undertaken here.

Table 7.1. Examples of MVA studies and projects for storage settings other than offshore EOR.

Setting \ Operation	Onshore	Offshore
Injection for storage in saline formations	Quest, IBPD, Gorgon and dozens of smaller fields	Sleipner, Sjøhvit, Tomakomai
Injection for storage in abandoned reservoir	Lacq/Rousse, Otway Phase 1	Goldeneye, Miller*
Injection for EOR/EGR	Denver Unit, West Ranch, Cranfield, Bell Creek, Hasings, and others	

* Goldeneye and Miller are feasibility studies

Table 7.2. General background on MVA (not specific to Offshore CO₂ EOR settings)

Reference	Short name	Key content
IPCC (2005)	IPCC Special report	
NETL (2012)	NETL Best Practices for MVA	Related to US regional Sequestration partnership experience MVA tools and US-based case studies
Cooper (2009)	CCP Technical Basis of CCS	Oilfield and CCS case studies oil industry expertise
Jenkins et al., (2015)	10 Years after IPCC update	Containment, conformance, and assurance monitoring, case studies

The extensive previous work on offshore monitoring has been focused on storage in saline formations or in hydrocarbon reservoirs without intent to produce was the topic of a previous CSLF report and a few key citations from that report are provided in Table 7.3. Monitoring of CO₂ storage in association with CO₂ EOR has also been recently been evaluated, however these projects have been focused on the by far most common setting for CO₂ EOR in onshore fields (Table 7.4).

Table 7.3. Resources on offshore monitoring

Reference	Short name	Key content
CSLF (2015)	CSLF – Offshore Storage review	An overview of status of offshore storage, with a focus on the current dominate stings in saline and depleted fields. Chapter 7 of this report reviews monitoring technologies
IEAGHG (2015)	IEAGHG Offshore monitoring review	A review of monitoring experience and options, with details on successful deployments.
Chadwick and Eiken (2013)	Sleipner experience	One of many papers on successful monitoring of 20 years of offshore CO ₂ storage in a saline formation associated with the Sleipner field in the North Sea. See additional papers cited in 5 and 6.
Hansen et al.,(2012)	Snøhvit experience	Overview of experience with offshore saline CO ₂ storage in association with the Snøhvit gas field in the Barents Sea.
Tanaka et al. (2014)	Tomakomai experience	Overview of planning offshore saline CO ₂ storage in a near shore setting in Japan.

Table 7.4. Resources on CO₂ EOR monitoring (with a focus on onshore settings)

Reference	Short name	Location	Key content
Occidental (2015)	OXY MRV* plan	Denver Unit, Wason field, Permian basin	Monitoring plan for a mature EOR operation
Eidan et al. (2015)	CSLF report on EOR-storage conversion	Various	Review of components of EOR, including monitoring.
Hitchon (2012)	Weyburn-Midale BMP**	Western Canadian sedimentary basin, Saskatchewan	EOR project important in development of MVA practices
Wolaver et al., (2013)	Comparing greenfield to brown field	US EOR onshore cases	Comparing monitoring options and best approaches in saline (greenfield) setting to reused settings (brownfield such as EOR)
Hill et al., (2013)	EOR as storage	US EOR onshore cases	Overview of function of EOR as geologic storage including some monitoring options
Ren et al., (2011)	Monitoring CO ₂ EOR and storage	Chinese experience, Jilin oilfield, China	A monitoring plan for optimizing production and assuring storage during an EOR pilot

* MRV=Monitoring, Reporting and Verification

** BPM=Best Practice Manual

The task of this chapter is to intersect the available information on MVA applied to storage offshore saline and depleted reservoirs and onshore for EOR to consider the monitoring options suitable for offshore EOR. Under this topic we consider roles and expectations for MVA for offshore EOR, the differences between EOR and storage, and the differences between offshore and onshore MVA programs.

7.1 Roles and expectations of Monitoring, Verification and Assessment for Offshore CO₂-EOR

Four main categories of motivations are listed here as drivers of MVA: 1) EOR operational needs, 2) regulatory requirements related to subsurface operations and wells, 3) greenhouse gas accounting requirements, and 4) risk and liability management. These motivations can overlap or one motivation can be considered a subset of another depending on the definition of the project and the nature of the regulatory structure.

MVA to meet EOR operational needs

Various data are commonly collected to optimize oil recovery in current CO₂ EOR operations (Lake, 1989; National Petroleum Council (NPC), 2011; Verm, 2015). In conventional operations where CO₂ is purchased and is available only in limited amounts, minimizing the ratio of CO₂ use per volume of oil recovered (known as utilization ratio) is important to project economics. Surveillance of the CO₂ flood operation is commonly practiced to assure that the CO₂ effectively contacts the oil and does not bypass oil and break through to production wells prematurely or excessively. In addition, managing the reservoir pressure to maintain conditions near or greater than minimum miscibility pressure are also used to increase recovery and decrease utilization ratio.

Although operator-to-operator differences are large, monitoring strategies most commonly collected to meet operational needs at conventional onshore EOR fields are:

- 1) intermittent or continuous wellhead and bottom-hole pressure for some or all injectors and producers; and
- 2) volume (and associated density data) for CO₂ injected and volumes of produced fluids.

Produced fluids from each well are commonly sent to a test facility on a regular (typically monthly) schedule so that the ratios of oil, water, and gas can be assessed. Further chemical testing can be used to quantify methane and other hydrocarbon gasses from CO₂ volumes. In addition, various types of oilfield surveillance such as injection and production profile logs, saturation logging using tools such as pulsed neutron, 3-D and 4D geophysical surveys, cross wells surveys, and tracer test programs have been widely used (Cooper, 2009). Although these tools are targeted to optimize CO₂ utilization, they can provide much of the basis for effective surveillance and accounting of storage on the reservoir. An example of how an existing CO₂ EOR monitoring program was accepted by the US Environmental Protection Agency (EPA) to document storage of anthropogenic CO₂ for accounting under the greenhouse gas emission accounting rule is presented by the Monitoring, Reporting and Verification (MRV) plan of OXY (Occidental, 2015).

Fluid flow models are often used to optimize CO₂ utilization in CO₂ EOR projects. However, because of the computation expense of simulation using a compositional model (one that represents the CO₂-oil interactions), it is common to simulate only representative injection-production well patterns, and extrapolate these data across the field, rather than conducting a whole-field simulation (Occidental, 2015).

It is not clear, at this time, how the optimization of CO₂ utilization will be conducted in offshore settings. Current offshore operations differ from onshore operation in that well spacing may be larger and the use of horizontal well components more common. In addition, other business models could substantively change operations. For example, in a future situation, a main driver for a project might be as CO₂ off-take, with EOR added as a less important cost recovery element. Alternatively, the increased cost and limitations of fluid handling in a platform or subsea installation might drive operational decisions away from current pattern flood models. Although no detailed plans are available for how to optimize an offshore CO₂-EOR flood, the possibility that operations might be different from current onshore operations is considered in this section.

Drilling and operational regulatory monitoring requirements

Regulatory requirements for offshore CO₂ EOR are described in Chapter 7 and may come from marine environmental protection regulations or from well drilling or hydrocarbon production laws applicable to the local jurisdictions. Most hydrocarbon regulation focuses on assurance of well integrity.

The criteria of how much hydrocarbon recovery is required to qualify as hydrocarbon recovery could be a consideration under conditions where a major purpose of CO₂ EOR is off-take from CO₂ capture storage. Current onshore CO₂ EOR pattern flood operations are designed with arrays of injectors and producers to form a pattern flood. Economic considerations such as the cost of CO₂ and the cost of CO₂ handling generally limit the amount of fluid injected, such that the reservoir pressure is maintained in the zone where CO₂ and oil are as miscible as possible; however, neither the area nor magnitude of the area of elevated pressure is increased over the life of the project. In most cases the volumetric ratio of total fluids injected to total fluids withdrawn is near 1:1 (Occidental, 2015).

MVA to meet greenhouse gas (GHG) accounting requirements

Monitoring to document storage efficiency and qualify any CO₂ leakage during or after the project operation may be a requirement triggered by the capture process. Under a GHG gas accounting requirement, many of the components of the monitoring program are similar to those detailed for all subsea GHG accounting (CSLF, 2015).

For CO₂ EOR, an additional component, accounting for CO₂ that is produced with the hydrocarbons is needed. In typical project onshore, produced CO₂ is commingled with new CO₂ arriving at the site and re-injected, a process known as recycle. Efficiency of recycle is specific to the operation, however, available reports indicate that the efficiency is high. The recycling operation is one of the unknowns in

design of future offshore EOR projects (Sections 4.3 – 4.4), and a process-specific accounting will be a requirement to complete the GHG accounting process.

Several other monitoring needs and options are likely to be different for offshore EOR compared to onshore EOR and offshore EOR compared to offshore storage; these are described in following sections.

Risk and liability management

Risk management can be a major motivation for implementation of monitoring. Selection of an MVA strategy needs to be closely tied to specific site, in terms of site characteristics, operational condition, and local receptors should leakage occur. These parameters can be integrated in a risk assessment (DNV, 2012). Such a risk assessment is described in detail in the CSLF report on offshore storage (CSLF, 2015), which provides a risk assessment framework, and data on risk to biota and water column risks. Offshore CO₂ EOR may have a different risk profile than offshore storage for several reasons: 1) presence of hydrocarbons and 2) active management of pressure can change risk. These differences are described in more detail in the following sections.

7.2 Differences between MVA for CO₂-EOR and storage of CO₂

A number of key differences in the risk profile are noted between CO₂ EOR and CO₂ storage (Table 7.5). These differences should trigger differences in the monitoring approach. Some differences result in a possibly lowered risk profile for CO₂ EOR than for a similar saline site. Parameters that lower risk include 1) active management of the lateral extent of the CO₂ plume and the area and magnitude of pressure elevation because of production; 2) better characterization of the injection zone because of operational data gained during production, such as porosity, permeability, connectivity, and boundary conditions in the reservoir; 3) already demonstrated effective trap and effective seal because of hydrocarbon trapping over geologic time, and 4) role of oil in trapping more CO₂ because of CO₂-oil miscibility than is trapped by dissolution in water.

The applicability of this list of parameters, which was developed with reference to onshore EOR operations to offshore should be critically assessed when applied to offshore. For example, the management of area of CO₂ and area and magnitude of pressure that is applied in an onshore pattern flood may not be as effective offshore if the well pattern or density does not exert the same degree of control. Onshore in a depleted field, the abundance of wells, including a large number of very old wells and previously plugged wells can create high risk and high cost to mitigate. This difference is likely to be decreased offshore, where wells are most commonly newer and fewer.

Table 7.5. Comparing risks for CO₂-EOR and storage of CO₂ (Adapted from Hill et al., 2013)

Risk Type	Storage only (saline)	EOR with incremental storage
Surface conditions	Greenfield (never used)	Brownfield – already impacted by past operations
CO ₂ management	Injection only	Injection, production, recycle
Pressure management	Significant risk, can be managed by water withdrawal	Pressure management is goal of EOR
CO ₂ trapping	Quality of seal is inferred	Quality of seal is proven
Solubility of CO ₂ in formation fluid	CO ₂ weakly soluble in brine	CO ₂ highly soluble in oil
Subsurface information density	Sparse information, few penetrations	Dense information from well penetrations and past operational history
Well failure	Few wells may lead to low risk	Abundant and older wells may increase risk *
Pore space access	Requires new legal mechanisms	Can be built on existing oil and gas precedent

Revenue to offset capture cost	No	Yes
Public acceptance	Questionable	Public more familiar with oil production

* Offshore wells may not be as old or as abundant as in onshore oil fields.

Several conditions specific to depleted reservoir settings should be considered in design of an EOR monitoring program (Wolaver et al., 2013). The presence of a local hydrocarbon accumulation as well as past production create perturbations of the environment. Past production may have perturbed the sea floor, the target zone, and possibly shallower zones by pressure depletion, fluid extraction and possible fluid cross-contamination. In addition, methane as well as higher hydrocarbons may be abundant in the reservoir under flood as well as shallower zones. Hydrocarbon anomalies can be the result of geologic seepage, creating geochemical anomaly around the reservoir or as a result of past production activities (e.g.: spills or overboating of fluids). Care should be taken to identify characteristics that would indicated leakage from reservoir depth and separate this signal from anomalies already present in the system. A wide array of geochemical markers including stable and radiogenic isotopic tracers of carbon, oxygen strontium, major and minor elements in fluids, noble gasses, and hydrocarbon characteristics may be useful, but are likely to be site specific.

The presence of methane can change the viability of detecting CO₂ migration using seismic methods. Seismic velocity can be related to gas saturation at low saturations, but at increased gas saturation the change in seismic response decreases and any change created by introduction of more gas can be difficult to detect. Shallow methane zones or residual methane in the reservoir can therefore mask CO₂ migration into the zone (Urosevic et al., 2011). This limitation should be dealt with through modelling likely response and allocation of optimized tools because seismic is seen as a high value approach to offshore MVA in general (CSLF, 2015).

Depleted hydrocarbon reservoirs may have long-term histories different from saline storage sites. Saline storage sites are conceptualized as being filled to a designed end and then entering closure and post-closure phases which may require various MVA activities. Hydrocarbon reservoirs, however, will contain hydrocarbons at the end of EOR. It is possible that in the long term these post-EOR depleted fields can be produced by new technologies not currently foreseen. Such an evolution should be considered in the accounting and monitoring strategies developed.

Time-lapse seismic methods have proven to be very valuable for the CO₂ storage projects (saline aquifers) offshore Norway (e.g. Chadwik et al., 2010; Furre & Eiken, 2014) where strong contrasts in acoustic properties between the water and CO₂ saturated portions of the reservoir allow excellent reservoir imaging. For CO₂ EOR projects, where the acoustic property contrast between CO₂ and hydrocarbon is much less, this level of success in time-lapse seismic imaging is likely to be significantly reduced. However, time-lapse imaging at the onshore CO₂-EOR project at Weyburn Canada (White, 2013) has proven successful. Furthermore, with developments in differentiating pressure and saturation effects from time-lapse seismic datasets (Landrø, 2001) the potential for successful seismic monitoring of offshore CO₂-EOR projects is significant.

7.3 Differences between MVA for onshore CO₂-EOR and offshore CO₂-EOR

Because no prototype of a typical offshore EOR field is available, it is difficult to know what differences in the risk profile and therefore the monitoring strategy may be. The following issues are raised for consideration:

Offshore CO₂-EOR may be deployed with a stronger initial emphasis on greenhouse gas accounting. It is possible that high and constant rates of CO₂ injection could be needed to achieve GHG goals. Onshore EOR traditionally minimizes the CO₂ usage, by maintaining a 1:1 rate of the volume of all fluids injected and all fluid withdrawn. CO₂ is augmented by injection of water (WAG process) and the amount of CO₂ brought to the site may decrease over time because of increased CO₂ recycling and

increased water to gas ratio (tapered WAG). High rates of CO₂ injection might elevate risk as compared to traditional onshore EOR by allowing CO₂ and elevated pressure to migrate outside of the area of the field under control by production. In addition, widely spaced wells typical of offshore settings might create large areas of elevated pressure than is typical onshore.

Onshore the traditional highest concern has been contamination of groundwater or surface water resources by brine that leaks from improperly completed wells. Offshore this concern can be lowered if release of brine to marine environments is acceptable. However, concern over leakage of hydrocarbons is of equal or perhaps even higher concern in marine environments than in onshore settings.

In some conventional offshore production settings produced brine is disposed of to the ocean rather than being reinjected into the subsurface. In other jurisdictions brine disposal to the marine environment is restricted and geological disposal is preferred. It is not yet clear how the brine handling options in the offshore setting will affect the operations for offshore CO₂-EOR projects. In addition, the environmental impacts of CO₂ dissolved in the brine to be disposed of may result in precipitation of metals due increased rock-water-CO₂ reaction. This issue should be considered (Carruthers, 2016).

Offshore well construction, with deviated wells and multilaterals will have an impact on optimization of MVA tools deployed. Risk profiles of such wells may be different than onshore wells. For example the number of wells offshore are typically lower and the well construction is newer than onshore. Some completion risks are unique to offshore wells (CSLF, 2015) and these should be dealt with in the monitoring plan. Costs for well re-entry are typically significantly higher offshore than onshore, and this will have a strong impact on optimization of MVA.

7.4 Transition CO₂-EOR to storage – impact on monitoring

The monitoring issues for CO₂-EOR projects wanting to transition from EOR to storage offshore will include (CSLF, 2013; Eidan et al., 2015):

- a. Assurance monitoring (where and how much CO₂ is in the storage reservoir).
- b. Requirement for more environmental monitoring (sensors in, or sampling from, the sedimentary succession above the reservoir, shallow potable-groundwater saline aquifers, soils and surface) over a larger Area of Review or Influence.
- c. Baseline monitoring prior to start of CO₂ injection.
- d. Monitoring after cessation of CO₂ injection for various periods of time, depending on regulations in the respective jurisdiction.

These activities are feasible with known technology and can be net by operators, but they will have cost impacts.

7.5 Conclusions

Offshore CO₂-EOR is much less mature than onshore CO₂-EOR and offshore storage of CO₂, both of which have decades long histories, and will have different risk profiles. This will require special considerations when designing an MVA programme for offshore CO₂-EOR. However, a range of monitoring technologies applied in the two other settings are applicable also to offshore CO₂-EOR. This review has not identified any technical barriers for proper monitoring of offshore CO₂-EOR fields.

8. REGULATORY REQUIREMENTS FOR OFFSHORE CO₂ UTILIZATION AND STORAGE

8.1 Introduction and scene-setting

CO₂-EOR offshore has yet to commence (except in Brazil) and therefore regulatory regimes have not been developed or tested. Regulatory regimes exist for CO₂ storage offshore, and there are regulatory regimes for CO₂-EOR onshore. This section will consider the regulatory issues for CO₂-EOR offshore by reviewing work done around this topic.

In terms of CO₂ geological storage offshore there have been significant international developments because this activity was viewed as otherwise unregulated and in certain project configurations was actually prohibited (e.g.: London Protocol and OSPAR). This international work started from the legal view that storage of CO₂ in the water column or sub-seabed may be dumping of waste in the marine environment. However, the international community determined that any use of CO₂ in the sub-seabed was not dumping, not therefore prohibited, and not needing specific regulation. Ergo any CO₂ used for EOR would not be covered by these CO₂-storage specific regulations. Therefore, the default is that any CO₂-EOR activity would come under any existing hydrocarbon production regulations, which would be jurisdiction specific. This would mean a regulatory environment based on CO₂ as a commodity rather than a waste; wastes are typically more heavily regulated, so this would be beneficial for CO₂-EOR. An example of this is the London Protocol's prohibition on export of waste, which currently means that CO₂ cannot be exported for storage (note that an amendment to change this is in place, but not in force due to a very slow rate of ratification). CO₂ exported for use in CO₂-EOR is not prohibited by this export prohibition. (Dixon 2009 and 2015).

A full description of the international regulations for CO₂ storage offshore are provided in the CSLF Report "Technical Barriers and R&D Opportunities for Offshore, Sub-Seabed Geologic Storage of Carbon Dioxide" CSLF (2015).

The ISO TC265 is currently working on the topic of CO₂-EOR and its Working Group 6 is drafting an international standard for CO₂-EOR projects to be considered as storage. This is expected to be focused on onshore but similar principles will apply offshore. Note that this draft standard has yet to be approved or made public (ISO, 2017; draft only, to be published).

The issues for CO₂-EOR projects wanting to transition from EOR to storage offshore will be similar to those onshore. These issues include challenges over site characterization and risk assessment and monitoring baseline measurements (required in advance for storage projects but not necessarily undertaken in advance for CO₂-EOR projects), pore space access/ownership/leasing (which may end at the end of EOR operations), and post-closure monitoring and liability issues (CCP4, 2016).

If carbon credits are sought there will be a requirement to demonstrate storage and retention of CO₂ from the atmosphere. Such regulatory requirements are in place in the EU and USA, and in the UNFCCC's Clean Development Mechanism. Therefore, if a CO₂-EOR project wishes to gain carbon credits, either during CO₂-EOR or when it transitions to straight storage, it will have to demonstrate storage and retention of CO₂ from the atmosphere by meeting the relevant regulatory requirements.

8.2 Examples of Specific National Regulatory Requirements

8.2.1 UK

The Scottish Centre for CCS undertook a review of existing regulations and guidelines covering UK North Sea offshore and concluded that "it would seem possible that CO₂-EOR activities would be regulated under existing laws and voluntary practices, with little or no amendments" (Carruthers, 2014).

A broader report by the Scottish Centre for CCS considers broader legal aspects for CO₂-EOR, and identified areas in the current UK and EU legislation that need to be addressed, although these were focussed on property rights and transboundary movement of CO₂, more generic issues (SCCS, 2015). One issue identified is the international requirements (London Convention, OSPAR, EU) for the CO₂ stream to be ‘overwhelmingly CO₂’. For CO₂-EOR the reinjected stream could be a wider mixture of fluids with the CO₂-EOR. Such mixtures and the flexibility in ‘overwhelmingly’ should be investigated.

8.2.2 United States

The U.S. offshore consists of submerged lands under the jurisdiction of the coastal States, as well as submerged lands that are under Federal jurisdiction, referred to as the Outer Continental Shelf (OCS). The OCS consists of 1.7 billion acres of submerged lands, subsoil, and seabed, lying between the seaward extent of the States’ submerged lands and the seaward extent of Federal jurisdiction. The U.S. Department of the Interior (DOI) authorizes and regulates the development of mineral resources (including oil and gas) and certain other energy and marine related uses on the OCS. Although oil and gas EOR operations occur on the OCS, none to-date have used CO₂.

The Presidential Interagency Task Force on Carbon Capture and Storage examined the existing U.S. regulatory framework and recommended (in 2010) the development of a comprehensive U.S. framework for leasing and regulating sub-seabed CO₂ storage operations on the OCS that addresses the broad range of relevant issues and applies appropriate environmental protections. However, this comprehensive framework has yet to be established; therefore, the existing regulatory framework is shared across multiple Federal agencies, including DOI and the U.S. Environmental Protection Agency (EPA), and may have jurisdictional gaps, including the transition from CO₂-EOR to sub-seabed geologic storage of CO₂.

The UIC Program defines multiple classes of injection wells, each with their own specific regulatory requirements. Oil and Gas operations using CO₂ for EOR are regulated as Class II Oil and Gas Related Injection Wells, and if after EOR operations are terminated and the wells are converted to CO₂ injection wells for geologic storage, the wells are regulated as Class VI Injection Wells used for Geologic Sequestration of CO₂. In 2010, the EPA promulgated regulations for its newly established UIC Class VI wells, which include specific requirements for site selection, well design and construction, and monitoring, verification, and accounting (MVA) of injectate-CO₂, and long-term monitoring even after CO₂ injection has ceased. The EPA has also developed guidance to support the Class VI regulatory requirements¹². Under these regulations (40 CFR § 144.19), operators of Class II wells are required to apply for Class VI permits when there is an increased risk to USDWs from Class VI compared to Class II operations. The EPA also published a memo (April 23, 2015) that discusses six key regulatory considerations when transitioning from Class II to Class VI wells.

8.2.3 Brazil

Brazil is important in this context because it has the only operational offshore CO₂-EOR project in the world. The state-owned oil company Petrobras operates the Lula oilfield offshore in the Santos Basin and injects CO₂ into producing oil reservoirs. This is undertaken within existing petroleum legislation, and there is no CCS regulation in place in Brazil. No carbon credits are sought for this activity.

8.2.4 Gulf Cooperation Council Countries

The IEAGHG report on economic barriers for CO₂-EOR considers regulatory barriers to a small extent, and for Gulf Cooperation Council Countries it concludes that CO₂-EOR activities are generally able to be regulated under legislation used to control oil and gas exploration and production. In all

¹² Class VI – Wells used for Geologic Sequestration of CO₂: <https://www.epa.gov/uic/class-vi-wells-used-geologic-sequestration-co2>

GCC countries, state-owned enterprises dominate and have full concessions of all oil and gas production, and to a large extent, downstream refining and petrochemical sectors. State-owned operators are generally self-regulating. It is not expected that a lack of national regulation poses a key hurdle to the development of CO₂-EOR projects in GCC countries. (Reference IEAGHG 2016).

8.3 Differences between regulatory frameworks for storage and EOR

CO₂-EOR is regulated by oil and gas or petroleum legislation, whereas CCS can be governed by a variety of regulations, depending on jurisdiction (CCS/GHG specific legislation; mining and mineral legislation; general environmental and impact assessment regulations). This also impacts on the competent authority. Two aspects of the different legislation are:

- Presently, CO₂-EOR projects are not required to undertake site analysis and evaluation to the same extent as CCS projects with respect to capacity and integrity, as well as monitoring. CO₂-EOR projects wishing to transition to CCS projects after cessation of oil production must bear this in mind.
- A CO₂-EOR project ends when the oil production ceases and the field is abandoned according to oil field regulations. If seeking to transition to a CCS project, there may be issues around liability and CO₂ ownership.
- Greenhouse gas emissions accounting requirements, including emissions connected to the recycling and injection processes and the potential for “leaked” CO₂.

8.4 Regulations on transition of CO₂-EOR to storage: What is lacking and recommendations how this may be achieved

Regulations on transition from a CO₂-EOR project to a CO₂ storage (CCS) project were treated by CSLF (2013) and CCP (2016). Although mainly concerned with onshore CO₂-EOR both studies concluded that *“There are no specific technological barriers or challenges per se in transitioning and converting a pure CO₂-EOR operation into CO₂ storage operation. The main differences between the two types of operations stem from legal, regulatory and economic differences between the two.”*

This review has not disclosed anything that invalidates this statement from applying to offshore CO₂-EOR vs. offshore CO₂ storage.

CCP (2016) examined regulations for CO₂ storage, CO₂-EOR and the transition between the two for the following jurisdictions: USA, the Canadian provinces Alberta, Saskatchewan and British Columbia, the European Union (EU), Australia and Brazil. It was found that EU is the only jurisdiction that has regulations for all three in place, as indicated in Table 8.1. Regulations for the transition from CO₂-EOR to CO₂ storage are the least developed.

Table 8.1. Overview of regulatory status of selected countries/regions (after CCP, 2016)

Regulation for	USA	Canada			EU	Australia	Brazil
		Alberta	Saskatchewan	British Columbia			
CO ₂ -EOR	In place	In place	In place	Discussions under way	In place	In place	In place
Transition	In development	Discussions under way	Discussions under way	No information	In place	No information	Discussions under way
CCS	In place	In place	In development	In development	In place	In place	Discussions under way

In conclusion, there is need for a clarification of the legislation for the transition from CO₂-EOR to offshore CO₂ storage (CSLF, 2013; CCP, 2016). Areas that require particular attention include:

1. Storage site evaluation and geological modelling;
2. Monitoring of the storage site, reporting, and verification;
3. Site closure conditions and post-closure stewardship and liability;
4. Conformance with national GHG inventory guidelines for CCS.

Regulators, relevant legal authorities, and policy makers should work with the industry to address the issues and develop the needed legislation and guidelines. Work on standards has already been started by ISO (2017; draft only, to be published).

8.5 Conclusions

In all regions considered here, it appears that CO₂-EOR activities can be regulated under existing oil and gas regulation, and regulatory uncertainty is not assumed to constitute a barrier to the broader deployment of the technique. However, if the intention is for the CO₂-EOR to demonstrate long-term storage, or is seeking an incentive such as carbon credits, additional CCS regulatory requirements will need to be met. These will meet the same challenges transitioning from CO₂-EOR to CO₂ storage onshore. In general, such transitional requirements do not exist, and the issues are now becoming well documented, see CCP4 (2016) for a comprehensive and up-to-date assessment.

One issue identified if storage regulations are to be applied to CO₂-EOR is the international requirements (London Convention, OSPAR, EU) for the CO₂ stream to be 'overwhelmingly CO₂'. Such mixtures in CO₂-EOR re-injected streams and the flexibility in 'overwhelmingly' should be investigated.

In conclusion, it appears that offshore CO₂-EOR activities can be regulated under existing oil and gas regulation, and regulatory uncertainty is not assumed to constitute a barrier to the broader deployment of the technique. However, if the intention is for the CO₂-EOR to demonstrate long-term storage, or is seeking an incentive such as carbon credits, additional CCS regulatory requirements will need to be met.

9. SUMMARY OF BARRIERS FOR DEPLOYMENT OF OFFSHORE CO₂-EOR

There are few, if any, technical barriers to offshore CO₂-EOR. However, there are significant barriers related to policy and infrastructure development including:

1. Access to sufficient and timely supply of CO₂. There are few, if any, developed sources of CO₂ close to the offshore fields amenable to CO₂-EOR. Building an infrastructure will require huge up-front investments and the coordination of several stakeholders. A one-on-one source to CO₂-EOR field linkage is likely to be more expensive per tonne CO₂ than a network, and to have low flexibility with respect to reduced need for fresh CO₂ and temporary stops in the CO₂ production.
2. Lack of business models for offshore CO₂-EOR. Establishing offshore CO₂ networks will create many interdependencies and commercial risks concerning both economics and liabilities. Risk- and cost-sharing will be needed.
3. Timing of the EOR operation. The effect of CO₂-EOR will be reduced as the field gets more mature and at some point the benefit will be insufficient. A slow development of CCS will also delay opportunities for offshore CO₂-EOR.

4. High investment costs. Significant modifications and additional equipment on the platforms will be needed to separate CO₂ from the produced oil and gas and to make existing wells and pipes resistant to CO₂ corrosion. Development of new technologies can reduce the need for modifications and new equipment, for example, better mobility control or sub-surface separation systems. Use of existing pipelines may also be a way to keep investment costs down.
5. Additional operational costs, OPEX, will result from the need to separate and recompress the recycled CO₂. New technologies are also likely to reduce the OPEX.
6. Loss of production while modifying facilities represents an additional up-front cost. The value of the production loss is also dependent on the required rate of return.
7. Uncertainties around regulations exist but are not assumed to constitute a barrier if petroleum regulations exist offshore. However, it is not clear what requirements different jurisdictions will place on monitoring the CO₂ in the underground, both during and particularly after closure, and for the case where the field transfers into a CO₂ storage project.
8. Uncertainties around the revenues, namely the oil price and the cost of CO₂. Low oil prices and high CO₂ cost for the operators will prevent offshore CO₂-EOR unless new business models and/or changed tax regimes are implemented to de-risk investments.
9. Uncertainties around the price of CO₂ the oil field operator must pay to the CO₂ supplier, including the price of the CO₂ itself and the transportation costs. The first will often be subject to negotiations between seller and buyer and could be influenced by CO₂ prices in a trading scheme.
10. Reservoir characteristics are usually well known for mature oil fields but there will still be uncertainties around reservoir performance and the potential for yield of additional oil.
11. Monitoring. While not being a barrier there will be different considerations to make and regulations to follow when comparing offshore CO₂-EOR/storage to onshore CO₂-EOR/storage.

10. RECOMMENDATIONS FOR OVERCOMING BARRIERS FOR OFFSHORE CO₂-EOR

The main recommendation from this work is that governments and industry should work together to:

1. Increase the pace in deployment of CCS. This is a prerequisite for offshore CO₂-EOR and needs action at the highest political level. Slow deployment may lead to missed windows of opportunity for CO₂-EOR.
2. Start planning regional hubs and transportation infrastructures for CO₂. Building the networks will require significant up-front investments and the coordination of stakeholders, including industries, business sectors, and authorities that will have to work together. The activities will include CO₂ capture at regional clusters of power and industrial plants, transportation of the CO₂ to hubs and to the individual receiving fields, and injection management. Preliminary studies of the feasibility of such systems have already started in some regions, most notably the Gulf of Mexico and the North Sea. Such studies must be followed up.
3. Develop business models for offshore CO₂-EOR. The literature has a few examples that provide some thoughts, but these need to be matured. The business models must include fiscal incentives, e.g.: in term of taxes or tax rebates.
4. Support RD&D to develop new technologies that will reduce the high investment and operational costs for CO₂ separation, compression, and injection.
5. Continue to develop regulations specific to offshore CO₂-EOR for jurisdictions that do not have these in place. These should include monitoring the CO₂ in the underground, both during and particularly after closure and guidelines for when the field transfers into a CO₂ storage site.

REFERENCES

- ARI, 2010. U.S. oil production potential from accelerated deployment of carbon capture and storage. Advanced Resources International, Inc., Arlington, VA USA, March 10, 2010 and a.f. <https://www.adv-res.com/pdf/v4ARI%20CCS-CO2-EOR%20whitepaper%20FINAL%204-2-10.pdf>
- ARI and Melzer Consulting, 2010. Optimization of CO₂ storage in CO₂ enhanced oil recovery projects. <http://www.adv-res.com/pdf/1006-optimization-of-co2-storage-in-co2-enhanced-oil-re.pdf>
- Augustsson H, Grinestaf GH, 2005. A study of IOR by CO₂ injection in the Gullfaks field, offshore Norway. In: The 13th European Symposium on Improved Oil Recovery
- Ayasse, C., A.M.Shahin, A. Ayasse, R. Ayasse, 2016: New Economical Process to Monetize High-CO₂ Natural Gas. SPE-183403-MS. <https://www.onepetro.org/conference-paper/SPE-183403-MS>
- Baker, R. W., K. Lokhandwala, 2008. Natural gas processing with membranes: an overview. Ind. Eng. Chem. Res., 47, 2109-2121
- Banks, J.P., T. Boersma, W. Goldthorpe (2017). Challenges related to carbon transportation and storage – showstoppers for CCS? GCCSI web publication 06 January 2017.. <https://www.globalccsinstitute.com/publications/challenges-related-carbon-transportation-and-storage---showstoppers-ccs>
- Berger, B., Kaarstad, O., & Haugen, H. A. (2004). Creating a large-scale CO₂ infrastructure for enhanced oil recovery. In *Seventh international conference on greenhouse gas control technologies (GHGT-7)*. Vancouver.
- Bertin, H.J., O.G. Apaydin, L.M. Castanier, and A.R. Kovscek, Foam Flow in Heterogeneous Porous Media: Effect of Cross Flow. SPE Journal, 1999(06).
- Birkedal, K.A.; Ersland, G.; Husebø, J.; Kvamme, B.; Graue, A. , 2010. Geomechanical stability during ch₄ production from hydrates - depressurization or co₂ sequestration with co₂-ch₄ exchange. In 44th U.S. Rock Mechanics Symposium and 5th U.S.-Canada Rock Mechanics Symposium, American Rock Mechanics Association: Salt Lake City, Utah, 2010.
- Blaker, T. et al., 2002. Foam for Gas Mobility Control in the Snorre Field: The FAWAG Project
- Brattekkås, B., Å. Haugen, G. Ersland, Ø. Eide, A. Graue, and M.A. Fernø, 2013. Fracture Mobility Control by Polymer Gel- Integrated EOR in Fractured, Oil-Wet Carbonate Rocks, in EAGE Annual Conference & Exhibition incorporating SPE Europec 2013: London.
- Buchanan, J.G., 1998. The exploration history and controls on hydrocarbon prospectivity in the Wessex basins, southern England, UK. Geological Society, London, Special Publications, 133(1): 19-37.
- Buchgraber, M., Castanier, L.M. and Kovscek, A.R., 2012. Microvisual Investigation of Foam Flow in Ideal Fractures: Role of Fracture Aperture and Surface Roughness, SPE Annual Technical Conference and Exhibition. Society of Petroleum Engineers, San Antonio, Texas, USA

Carbon Capture Journal, 2007. <http://www.carboncapturejournal.com/news/co2-for-eor-not-commercially-viable---statoil/2184.aspx?Category=al>

Carruthers, K., 2014. Environmental Impacts of CO₂-EOR. June 2014. <http://www.sccs.org.uk/images/expertise/reports/co2-eor-jip/SCCS-CO2-EOR-JIP-WP4-Environmental-Impacts.pdf>

Carruthers, K., 2016, Metal mobility in sandstones and the potential environmental impacts of offshore geologic storage, University of Edinburgh PhD, 266 p.

Castanier, L.M. and Hanssen, J.E., 1995. Foam Field Tests: State of the Art and Critical Review, 8th European IOR Symposium, Vienna, Austria.

CATO (2016). Transportation and unloading of CO₂ by ship – a comparative assessment. WP9 Final Report. <https://www.co2-cato.org/publications/library1/transportation-and-unloading-of-co2-by-ship-a-comparative-assessment>

Cavanagh, A., and P. Ringrose, 2014. Improving Oil Recovery and Enabling CCS: A Comparison of Offshore Gas-recycling in Europe to CCUS in North America. Energy Procedia, 63, 7677-7684

Chen, Y., A.S. Elhag, B.M. Poon, L. Cui, K. Ma, S.Y. Liao, A. Omar, A. Worthen, G.J. Hirasaki, Q.P. Nguyen, and K.P. Johnston, Ethoxylated Cationic Surfactants For CO₂ EOR In High Temperature, High Salinity Reservoirs, in SPE IOR Symposium. 2012, Society of Petroleum Engineers: Tulsa, Oklahoma.

CCP (2016) Best Practice in Transitioning from CO₂ EOR to CO₂ Storage. Reprt for CCP\$ Policies and Incentives Group. ERM. <http://www.co2captureproject.org/viewresult.php?downid=228>

Chadwick R.A. and Eiken, O. 2013. Offshore CO₂ storage: Sleipner natural gas field beneath the North Sea (Chapter 10). In: Gluyas, J. & Mathias, S. (eds) *Geological storage of carbon dioxide (CO₂) – Geoscience, technologies, environmental aspects and legal frameworks*. Woodhead Publishing Ltd. ISBN 978-0-85709-427-8, 227-250.

Chadwick, A., Williams, G., Delepine, N., Clochard, V., Labat, K., Sturton, S., ... & Arts, R. 2010. Quantitative analysis of time-lapse seismic monitoring data at the Sleipner CO₂ storage operation. *The Leading Edge*, 29(2), 170-177.

Chiyoda Corporation (2011). Preliminary feasibility study on CO₂ carrier for ship-based CCS. <http://hub.globalccsinstitute.com/publications/preliminary-feasibility-study-co2-carrier-ship-based-ccs>

Chiyoda Corporation (2012). Preliminary feasibility study on CO₂ carrier for ship-based CCS. Phase 2: unmanned offshore facility. <http://hub.globalccsinstitute.com/node/94501>

Cooper, C. (Ed.), 2009. A technical basis for CO₂ storage. CO₂ Capture Project, CPL Press, UK www.co2captureproject.org

CSLF, 2013. Technical challenges in the conversions of CO₂-EOR projects to CO₂ storage projects. https://www.cslforum.org/cslf/sites/default/files/documents/CO2-EORtoCCS_FinalReport.pdf

CSLF, 2015. Technical Barriers and R&D Opportunities for Offshore, Sub-Seabed Storage of CO₂ http://www.cslforum.org/publications/documents/OffshoreStorageTaskForce_FinalCombinedReport.pdf

- Cui, L. et al., 2014. Adsorption of a Switchable Cationic Surfactant on Natural Carbonate Minerals. Society of Petroleum Engineers.
- De Visser, E., Hendriks, C., Barrio, M., Mølnvik, M. J., de Koeijer, G., Liljemark, S., & Le Gallo, Y. (2008). Dynamis CO₂ quality recommendations. *International Journal of Greenhouse Gas Control*, 2(4), 478-484.
- Dixon, T., A. Greaves, J. Thomson, O. Christophersen, C Vivian, C., 2009. International Marine Regulation of CO₂ geological storage. Developments and implications of London and OSPAR. GHGT-9. Energy Procedia 1 (2009), 4503–4510.
- Dixon, T., S.T. McCoy, I. Havercroft, 2015. Legal and Regulatory Developments on CCS International Journal of Greenhouse Gas Control 40 (2015) 431–448
- DNV, 2012. Recommended proactive, DNV-RP-J203, Geological Storage of Carbon Dioxide. Available online: <http://rules.dnvgl.com/docs/pdf/DNV/codes/docs/2013-07/RP-J203.pdf>
- Eggen, S. og P.H. Nøkleby, 2015. Økt oljeutvinning med CO₂ på norsk sokke . Paper issued in www.geoforskning.no 29th of September 2015. <http://geoforskning.no/nyheter/olje-og-gass/1042-okt-oljeutvinning-med-co2-pa-norsk-sokkel>
- EI (Energy Institute), 2013. Research Report: Hazard Analysis for Offshore Carbon capture Platforms and Offshore Pipelines. <https://www.globalccsinstitute.com/publications/hazard-analysis-offshore-carbon-capture-platforms-and-offshore-pipelines>
- Eide, Ø., M.A. Fernø, Z. Karpyn, Å. Haugen, and A. Graue, 2013. CO₂ injections for enhanced oil recovery visualized with an industrial CT-scanner, in 17th European Symposium on Improved Oil Recovery 2013: St. Petersburg, Russia.
- Eidan, A. A., S. Bachu, L.S. Melzer, L.I. Eide, M. Ackiewicz. 2015, Technical challenges in the conversion of CO₂ EOR projects to storage projects, SPE Enhanced Oil Recovery Conference held in Kuala Lumpur, Malaysia, 11–13 August 2015., SPE 174575 DOI <http://dx.doi.org/10.2118/174575-MS>
- Elhag, A.S. et al., 2014. Switchable Amine Surfactants for Stable CO₂/Brine Foams in High Temperature, High Salinity Reservoirs. Society of Petroleum Engineers.
- Elsam, Kinder Morgan and Statoil (2003) <http://www.co2.no/download.asp?DAFID=17&DAAID=6>
- Energy Research Partnership, 2015. Prospects for CO₂-EOR in the UKCS. http://erpuk.org/wp-content/uploads/2015/10/ERP_CO2-EOR-Report-Oct-2015.pdf
- Enick, R. M., Olsen, D. K., Ammer, J. R., & Schuller, W., 2012. Mobility and Conformance Control for CO₂ EOR via Thickeners, Foams, and Gels -- A Literature Review of 40 Years of Research and Pilot Tests. Society of Petroleum Engineers. doi:10.2118/154122-MS
- Ersland, G., M.A. Fernø, A. Graue, B.A. Baldwin, and J. Stevens, 2010. Complementary imaging of oil recovery mechanisms in fractured reservoirs. *Chemical Engineering Journal*, 2010. 158(1): p. 32-38.
- Esposito, R.A, L.S. Monroe, J.S.Friedman (2011), Deployment models for commercialized carbon capture and storage. *Environ Sci Technol*. 2011 Jan 1;45(1):139-46. doi: 10.1021/es101441a. Epub 2010 Aug 19. <http://pubs.acs.org/doi/pdfplus/10.1021/es101441a>

Farajzadeh, R., A. Andrianov, R. Krastev, G. Hirasaki, and W.R. Rossen, 2012. Foam-Oil Interaction in Porous Media: Implications for Foam Assisted Enhanced Oil Recovery, in SPE EOR Conference at Oil and Gas West Asia. 2012, Society of Petroleum Engineers: Muscat, Oman.

Farajzadeh, R., Wassing, B.M. and Boerrigter, P.M., 2012. Foam assisted gas–oil gravity drainage in naturally-fractured reservoirs. *Journal of Petroleum Science and Engineering*, 94–95(0): 112-122.

Fernø, M.A., A. Haugen, and A. Graue, 2012. Surfactant Prefloods for Integrated EOR in Fractured, Oil-Wet Carbonate Reservoirs, in SPE Annual Technical Conference and Exhibition. 2012, Society of Petroleum Engineers: San Antonio, Texas, USA.

Fernø, M.A., J. Gauteplass, M. Pancharoen, Å. Haugen, A. Graue, A.R. Kavscek, and G.J. Hirasaki. Experimental Study of Foam Generation, Sweep Efficiency and Flow in a Fracture Network, at SPE ATCE, Amsterdam, 27-29 Oct., 2014.

Firoozabadi, A., 1994. Miscible Displacement in Fractured Porous Media: Part I--Experiments. Society of Petroleum Engineers. doi:10.2118/27743-MS

Furre, A. K., & Eiken, O. (2014). Dual sensor streamer technology used in Sleipner CO₂ injection monitoring. *Geophysical Prospecting*, 62(5), 1075-1088.

Gauteplass, J., H. Follesø, A. Graue, A.R. Kavscek, and M.A. Fernø, 2013. Visualization of Pore-Level Displacement Mechanisms during CO₂ Injection and EOR Processes, in 17th European Symposium on Improved Oil Recovery 2013: St. Petersburg, Russia.

GCCSI, 2015). The global status of CCS 2015. Volume 3 CCS technologies. Accessible to members of GCCSI.

GCCSI, 2016a. Understanding industrial CCS hubs and clusters. Special report.
<http://www.globalccsinstitute.com/publications/industrial-ccs>

GCCSI, 2016b. The global status of CCS 2016. Volume 3 CCS technologies. Accessible to members of GCCSI.

Chan, Z. P., N.M. Yusop, M. Abai, S. M. Shariff, S. M., M.A. Ishak, M. A. 2014. CO₂ removal from natural gas using membrane contactor. OTC-24935-MS. OTC Asia March 2014.

Godec, M.L. 2011. Global Technology Roadmap for CCS in Industry. Sectoral Assessment. CO₂ Enhanced Oil Recovery. Report prepared for the United Nations Industrial Development Organization by Advanced Resources Institute, Inc. <https://hub.globalccsinstitute.com/publications/global-technology-roadmap-ccs-industry-sectoral-assessment-co2-enhanced-oil-recovery-19>

Goodyear, S. G., M.P. Koster, K.A. Marriott, A. Paterson, A.W. Sipkema, A. W., I.M. Young, 2011. Moving CO₂ EOR Offshore. SPE 144939. <https://www.onepetro.org/conference-paper/SPE-144939-MS>

Graue, A., Kvamme, B., Baldwin, B. A., Stevens, J., Howard, J., Aspenes, E., ... Zornes, D., 2006. Environmentally Friendly CO₂ Storage in Hydrate Reservoirs Benefits From Associated Spontaneous Methane Production. Offshore Technology Conference. doi:10.4043/18087-M

Graue, A.; Kvamme, B.; Baldwin, B.; Stevens, J.; Howard, J.J.; Aspenes, E.; Ersland, G.; Husebo, J.; Zornes, D. Mri, 2008. Visualization of spontaneous methane production from hydrates in sandstone core plugs when exposed to co₂. *SPE Journal* 2008, 13, 146–152.

Grigg, R.B. and Schechter, D.S., 1997. *State of the Industry in CO₂ Floods*. Society of Petroleum Engineers.

Grimstad, A.-A., T. Holt, E. Lindeberg, and S. Polak, 2012. CO₂ for EOR and storage in Norwegian oil fields in the North Sea

Ha, G.T, N. D. Tran, , H. H. Vu, S. Takagi, H. Mitsuishi, , A. Hatakeyama, T. Uchiyama, , Y. Ueda, T. V. Nguyen, T. N. Phan, H. N. Nguyen, T. H. Nguyen, Q. M. Dinh, 2012. Design & Implementation of CO₂ Huff-n-Puff Operation in a Vietnam Offshore Field. *SPE 161835*, Abu Dhabi International Petroleum Exhibition & Conference Abu Dhabi, UAE, 11–14 November 2012

Hansen, O., Gilding, D., Nazarian, B., Osdal, B., Ringrose, P., Kristoffersen, J-B., Eiken, O., Hansen, H., 2012, Snøhvit: The history of injecting and storing 1 Mt CO₂ in the fluvial Tubåen Fm. *Energy Procedia*, 37, 3565 – 357

Harouaka, A., Trentham, B., & Melzer, S. (2013). Long overlooked residual oil zones (ROZ's) are brought to the limelight. In *SPE Unconventional Resources Conference Canada*. Society of Petroleum Engineers.

Haugen, Å., M.A. Fernø, Ø. Bull, and A. Graue, 2010. Wettability Impacts on Oil Displacement in Large Fractured Carbonate Blocks. *Energy & Fuels*, 2010. 24(5): p. 3020-3027.

Haugen, Å., Fernø, M.A., Graue, A. and Bertin, H.J., 2012. Experimental Study of Foam Flow in Fractured Oil-Wet Limestone for Enhanced Oil Recovery. *SPE Reservoir Evaluation & Engineering*, 15(2): pp. 218-228.

Haugen, Å., N. Mani, S. Svenningsen, B. Brattekkås, A. Graue, G. Ersland, and M. Fernø, 2014. Miscible and Immiscible Foam Injection for Mobility Control and EOR in Fractured Oil-Wet Carbonate Rocks. *Transport in Porous Media*, 2014. 104(1): p. 109-131.

Hill, B., Hovorka, S, and Melzer, S, 2013, Geologic carbon storage through enhanced oil recovery, *Energy Procedia* 37, p 6808 – 6830

Hitchon, B. (Ed). 2012. Best practices for validating CO₂ geological storage: Observations and guidance from the IEAGHG Weyburn-Midale CO₂ monitoring and storage project. Geoscience publishing, Alberta, Canada. pp 353.

Holt, T., E. Lindberg, D. Wessel-Berg, 2009. EOR and CO₂ disposal – economic and capacity potential in the North Sea. *Energy Procedia* 1 (2009) 4159 – 4166

Hustad, C. W., and Austell, J. M., 2004. Mechanisms and incentives to promote the use and storage of CO₂ in the North Sea. *European Energy Law Report I*, Intersentia, 355-380.

IEA, 2016a. 20 years of carbon capture and storage - Accelerating future deployment. International Energy Agency, Paris.

IEA, 2016b. *Energy Technology Perspectives 2016*. International Energy Agency, Paris.

IEAGHG, 2009. CO₂ Storage in Depleted Oilfields: Global Application Criteria for Carbon Dioxide Enhanced Oil Recovery, Report 2009/12, December 2009.

http://www.ieaghg.org/docs/General_Docs/Reports/2009-12.pdf

IEAGHG, 2015. Offshore Monitoring for CCS Projects, Report 2015/02, May 2015.

http://www.ieaghg.org/docs/General_Docs/Reports/2015-02.pdf

IEAGHG, 2016. Regional assessment of barriers to CO₂ enhanced oil recovery in the North Sea, Russia and the GCC states. IEAGHG Report 2016/11, October 2016.

<http://www.ieaghg.org/publications/technical-reports/129-publications/new-reports-list/718-2016-11>

Imaev, S. Z., L.A. Bagirov, V.E. Borisov, E.V. Voytenkov, 2014. New low temperature process of CO₂ recovery from natural gases. SPE- 171427. <https://www.onepetro.org/conference-paper/SPE-171427-MS>

IPCC, 2005 - Bert Metz, Ogunlade Davidson, Heleen de Coninck, Manuela Loos and Leo Meyer (Eds.) Cambridge University Press, UK. pp 431.

ISO, 2016. Carbon dioxide capture, transportation and geological storage — Pipeline transportation systems. ISO 27913:2016

ISO, 2017 Carbon Dioxide Capture, Transportation and Geological Storage – Carbon Dioxide Storage using Enhanced Oil Recovery (CO₂-EOR). ISO/CD 27916, Annex A (Committee Draft of international standard as of March 2017)

Jenkins, C., Chadwick, A., and Hovorka, S. D., 2015, The state of the art in monitoring and verification--Ten years on: International Journal of Greenhouse Gas Control, v. 40, p. 312-349,

<http://doi.org/10.1016/j.ijggc.2015.05.009>

Jonas, T.M., Chou, S.I. and Vasicek, S.L., 1990. Evaluation of a CO₂ Foam Field Trial: Rangely Weber Sand Unit. Society of Petroleum Engineers.

Kalahari, Y. and Hatakeyama, A., 2016. Offshore CO₂-EOR Pilot Project in Vietnam. Presented at Carbon Sequestration Leadership Forum (CSLF), Tokyo, Japan, October 5, 2016

<https://www.cslforum.org/cslf/sites/default/files/documents/tokyo2016/Kawahara-VietnamEORProject-Workshop-Session1-Tokyo1016.pdf>

Karimaie, H., Nazarian, B., Aurdal, T., Nøkelby, P. H., and Hansen, O. 2016. Simulation Study of CO₂ EOR and Storage Potential in a North Sea Reservoir. GHGT-13 Conference, 14-18 November 2016, Lausanne, Switzerland.

Kemp, A.G., S. Kasim, 2013. The economics of CO₂-EOR cluster developments in the UK Central North Sea. Energy Policy 62 (2013) 1344 - 1355

Kovscek, A.R., Tretheway, D.C., Persoff, P. and Radke, C.J., 1995. Foam flow through a transparent rough-walled fracture. Journal of Petroleum Science and Engineering, 17: 75-86.

Kreft, E., Brouwer, G. K., Hofstee, C., Wildenborg, A. F. B., Audigane, P., Gozalpour, F., ... & Geel, C. R. (2006). Results of the Second Test Program in K12-B, a Site for CO₂ Storage and Enhanced Gas Recovery. In *68th EAGE Conference and Exhibition incorporating SPE EUROPEC 2006*.

Kvamme, B.; Graue, A.; Buanes, T.; Kuznetsova, T.; Ersland, G., 2007. Storage of CO₂ in natural gas hydrate reservoirs and the effect of hydrate as an extra sealing in cold aquifers. *International Journal of Greenhouse Gas Control*, 1, 236–246.

Landrø, M. (2001). Discrimination between pressure and fluid saturation changes from time-lapse seismic data. *Geophysics*, 66(3), 836-844.

Lake, L.W. 1989, *Enhanced oil recovery*. ISBN 978132816014, Prentice Hall, Englewood Cliffs, NJ.

Li, Z. et al., 2009. Enhance Foam Flooding Pilot Test in Chengdong Of Shengli Oilfield: Laboratory Experiment And Field Performance. *International Petroleum Technology Conference*

Li, S., S.J. Zhou, T. Pyrzynski, H. Meyer, Y. Ding, B. Bikson, 2015. PEEK Hollow Fiber Membrane Contactor (HFMC) Process for CO₂ Capture. Presentation for California Energy Commission's workshop, April 2015.

http://www.energy.ca.gov/research/notices/2015-04-16_workshop/presentations/GTI_2015_Presentation_to_CEC_Workshop.pdf

Lindeberg, E., A-A. Grimstad, P. Bergmo, D. Wessel-Berg, M. Torsæter, T. Holt, 2017. *Energy Procedia* 00 (2017) 000 - 000

Lopera Castro, S.H., Restrepo, A. and Ocampo, A., 2009. Use of Divergent Fluids as an Alternative For Enhanced Recovery in Naturally Fractured Cores. *Society of Petroleum Engineers*.

Maersk Tankers (undated). <http://www.maersktankers.com/activities/pages/co2%20shipping.aspx>

Makkuni, A., S. Li, T. Tamale, S.J. Zhou, H. Meyer, Y. Ding, B. Bikson, B. 2013. Mathematical Modeling of Hollow Fiber Gas-Liquid Membrane Contactors for Acid Gas Removal. Presentation at AIChE Annual Meeting, November 2013, San Francisco.

Malik, Q. M., & Islam, M. R., 2000. Potential of Greenhouse Gas Storage and Utilization Through Enhanced Oil Recovery in Canada. *World Petroleum Congress*.

Malone, T., Kuuskraa, V., DiPietro, P., 2014. CO₂-EOR Offshore Resource Assessment, report DOE/NETL- 2014/1631, 2014, 90 pp. http://www.netl.doe.gov/energy-analyses/temp/FY14_CO2-EOROffshoreResourceAssessment_060114.pdf

Markussen P, Austell JM, Hustad CW., 2002. A CO₂-infrastructure for EOR in the North Sea (CENS): macroeconomic implications for host countries. In: *The 6th International Conference on GHG Control Technologies*, Kyoto, No. 324.

Martinez, J. (1999). CO₂ Gas Lift - Is It Right For You? *Society of Petroleum Engineers*. doi:10.2118/52163-MS

McLendon, W.J., P. Koronaios, S. McNulty, R.M. Enick, G. Biesmans, A.N. Miller, L.C. Salazar, Y. Soong, V. Romanov, and D. Crandall, Assessment of CO₂-Soluble Surfactants for Mobility Reduction using Mobility Measurements and CT Imaging, in *SPE IOR Symposium*. 2012, Society of Petroleum Engineers: Tulsa, Oklahoma.

Melzer, L. S., Kuuskraa, V. A., & Koperna, G. J. (2006). The origin and resource potential of residual oil zones. In *SPE Annual Technical Conference and Exhibition*. Society of Petroleum Engineers.

MPE (Ministry of Petroleum and Energy, Norway), 2010. Enhanced recovery on the Norwegian continental shelf (in Norwegian).

https://www.regjeringen.no/globalassets/upload/oed/pdf_filer/oktutvinning.pdf

MPE, 2016. Feasibility study for full-scale CCS in Norway.

http://www.gassnova.no/no/Documents/Feasibilitystudy_fullscale_CCS_Norway_2016.pdf

Mukherjee, J. et al., 2014. CO₂ Foam Pilot in Salt Creek Field, Natrona County, WY: Phase I: Laboratory Work, Reservoir Simulation, and Initial Design, SPE Improved Oil Recovery Symposium. Society of Petroleum Engineers, Tulsa, Oklahoma, USA

National Petroleum Council, 2011, North American Resource Development Study, onshore conventional oil including EOR Paper #1-5, Prepared by the Onshore Oil & EOR Subgroup of the Resource & Supply Task Group, http://www.npc.org/Prudent_Development-Topic_Papers/1-5_Onshore_Conventional_Oil_Incl_EOR_Paper.pdf

Nazarian, B., Cavanagh, A., Ringrose, P. and Paasch, B. 2014. Composition Swing Injection for CO₂ Storage and EOR, SPE paper 171798-MS presented at the Abu Dhabi International Petroleum Exhibition and Conference, Abu Dhabi, UAE, 10-13 November 2014.

NETL, 2012. Best Practices for Monitoring, Verification, and Accounting of CO₂ Stored in Deep Geologic Formations 2012 Update, DOE/NETL-2012/1568 Report, October 2012.

Norwegian Petroleum Directorate (NPD), 2014 CO₂ Storage Atlas,

<http://www.npd.no/Publikasjoner/Rapporter/CO2-samleatlas/>

Netušil, M. and Ditl, P. 2012. Natural Gas Dehydration. Chapter from the book Natural Gas - Extraction to End Use. Published by INTECH (<https://www.intechopen.com/books/natural-gas-extraction-to-end-use>). Chapter access: <http://dx.doi.org/10.5772/45802>. <https://cdn.intechopen.com/pdfs-wm/36624.pdf>.

Occidental Permian Ltd. /US EPA, 2015, Oxy Denver Unit Co₂ Subpart RR Monitoring, reporting and verification (MRV) plan, https://www.epa.gov/sites/production/files/2015-12/documents/denver_unit_mrv_plan.pdf

Osdal, B., & Alsos, T. 2010. Norne 4D and Reservoir Management—The keys to success. In 72nd EAGE Conference and Exhibition incorporating SPE EUROPEC 2010.

Panahi, H., 2004. Improving the Recovery Factor of Heavy Crude Reservoirs by Co-injecting CO₂ and Other Conventional Gaseous Injecting Materials at Immiscibility Condition with Foam. Society of Petroleum Engineers.

Pancharoen, M., Ferno, M.A. and Kovscek, A.R., 2012. Modeling foam displacement in fractures. Journal of Petroleum Science and Engineering, 100: 50-58.

Pershad, H., E. Durusut, A. Crerar, D. Black, E. Mackay, P. Olden (2013) Economic impacts of CO₂-enhanced oil recovery for Scotland. Element Energy report to Scottish Enterprise. Published 16 October 2013. <https://www.scottish-enterprise.com/knowledge-hub/articles/publication/co2-enhanced-oil-recovery>. Last accessed 02 Feb. 2017

Prieditis, J. and Paulett, G.S., 1992. CO₂-Foam Mobility Tests at Reservoir Conditions in San Andres Cores. Society of Petroleum Engineers.

- Pöyry and Teesdide Collective (2017). A business case for a UK industrial CCS support mechanism. A Pöyry report on behalf of and in partnership with the Teesdide Collective. February 2017. <http://www.teessidecollective.co.uk/teesside-collective-report-a-business-case-for-a-uk-industrial-ccs-support-mechanism/>
- Reid, W., 2015. A Selective Literature Review of CO₂ EOR in the UK North Sea Continental Shelf. <https://www.thecrownstate.co.uk/media/501905/ei-literature-review-of-co2-eor-in-the-uk-north-sea-continental-shelf.pdf>
- Ren, S., A. Niu, B. Ren, Y. Li, W. Kang, G.Chen, H. Zhang, H. Zhang. 2011. Monitoring on Co₂ EOR and storage ion a CCS demonstration project of Jilin Oilfield China, SPE 145440 PE Annual Technical Conference and Exhibition held in Denver, Colorado, USA, 30 October–2 November 2011.
- Ryoo, W., Webber, S.E. and Johnston, K.P., 2003. Water-in-Carbon Dioxide Microemulsions with Methylated Branched Hydrocarbon Surfactants. *Industrial & Engineering Chemistry Research*, 42(25): 6348-6358.
- Salim, M., J. Harley, Z. Faizal, 2012. Process Design Aspects for Taking CO₂ Enhanced Oil Recovery Offshore. SPE 155527. SPE EOR Conference 2012. <https://www.onepetro.org/conference-paper/SPE-155527-MS>
- Sanders, A. et al., 2012. Implementation of a CO₂ Foam Pilot Study in the SACROC Field: Performance Evaluation, SPE Annual Technical Conference and Exhibition. Society of Petroleum Engineers, San Antonio, Texas, USA
- SCCS, 2015. CO₂ storage and Enhanced Oil Recovery in the North Sea. Securing a low-carbon future for the UK. CO₂-EOR Joint Industry Project. <http://www.sccs.org.uk/expertise/reports/co2eor-joint-industry-project>. (Accessed 30 January 2017)
- Scholes, C. A., G.W. Stevens, S.E. Kentish, 2012, Membrane gas separation applications in natural gas processing. *Fuel* 96 (2012) 15-28
- Skagestad, R., N. Eldrup, H.R. Hansen, S. belfroid, A. Mathisen, A. Lach, H.A. Haugen (2014): Ship transport of CO₂. Status and Technology Gaps. Tel-Tek report no. 2214090. http://www.gassnova.no/no/Documents/Ship_transport_TelTEK_2014.pdf
- Smith, D.H. (1988). Injectivity and Surfactant-Based Mobility Control, Surfactant-Based Mobility Control. ACS Symposium Series. American Chemical Society, pp. 429-438.
- Steffensen, I., & Karstad, P. I. (1996). Norne Field Development - Fast Track From Discovery to Production. Society of Petroleum Engineers. doi:10.2118/30148-JPT
- Stewart, R.J. and S. Haszeldine (2014) Carbon accounting for carbon dioxide enhanced oil recovery. <http://www.sccs.org.uk/expertise/reports/co2eor-joint-industry-project><http://www.sccs.org.uk/images/expertise/misc/SCCS-CO2-EOR-JIP-Carbon-Balance.pdf> (Accessed 14 March 2017)
- Stewart, R. J., S. Haszeldine, M. Wilkinson, G. Johnson, G. (2014). CO₂ Enhanced Oil Recovery from the Residual Zone - A Sustainable Vision for North Sea Oil Production. In *EGU General Assembly Conference Abstracts* (Vol. 16, p. 10988).

- Talebian, S.H., Masoudi, R., Tan, I.M. and Zitha, P.L.J., 2013. Foam assisted CO₂-EOR; Concepts, Challenges and Applications, SPE Enhanced Oil Recovery Conference. Society of Petroleum Engineers, Kuala Lumpur, Malaysia.
- Tanaka, Y., Abe, M., Sawada, Y., Tanase, D., Ito, T., Kasukawa, T., 2014. Tomakomai CCS Demonstration Project in Japan, 2014 Update, *Energy Procedia* 63, 6111 – 6119
- Thompson, J. L., & Mungan, N., 1969. A Laboratory Study of Gravity Drainage in Fractured Systems Under Miscible Conditions. Society of Petroleum Engineers. doi:10.2118/2232-P
- Trivedi, J.J. and Babadagli, T., 2008. Efficiency of diffusion controlled miscible displacement in fractured porous media. *Transport in Porous Media*, 71(3): 379-394.
- Uchiyama, T., Mitsubishi, H., Ueda, Y., A. Nishizaki, H. Okabe, S. Takagi, , H. Mitsuiishi, Y. Kawahara, L. Huy, P. N. Trung, N. H. Trung, N. V. Toan, N. N. Hoan, 2012 . Evaluation of a Vietnam Offshore CO₂ Huff-n-Puff Test. SPE154128. SPE Symposium on Improved Oil Recovery, Tulsa, Oklahoma, USA, 14–18 April
- Ueda, Y. et al., 2013, CO₂-EOR Huff ‘n’ Puff Pilot Test in Rang Dong Oilfield, offshore Vietnam, *Journal of the Japanese Association for Petroleum Technology*, Vol. 78, No.2, 188-196
- Urosevic, M., Pevzner, R., Shulakova, V., Kepic, A., Sharma, S. (2011). Seismic monitoring of CO₂ injection into a depleted gas reservoir Otway Basin Pilot Project, Australia. *Energy Procedia* 2011, v. 4, p. 3550-3557.
- U.S. Department of Energy, National Energy Technology Laboratory, 2010. Storing CO₂ and Producing Domestic Crude Oil with Next Generation CO₂-EOR Technology: An Update, prepared by Advanced Resources International, Publication Number: DOE/NETL-2010/1417, April 2010.
- Van Golf-Racht, T.D., 1982. “Fundamentals of fractured reservoir engineering”, *Developments in Petroleum Science*, Volume 12, Pages 3-710 (1982)
- Vassenden, F. and T. Holt, 2000. Experimental Foundation for Relative Permeability Modeling of Foam. *SPE Res. Eng. and Eval*, 2000. 3(2): p. 179-185.
- Verma, M. K., 2015, *Fundamentals of Carbon Dioxide-Enhanced Oil Recovery (CO₂-EOR)—A Supporting Document of the Assessment Methodology for Hydrocarbon Recovery Using CO₂-EOR Associated with Carbon Sequestration*, USGS open file report 2015-1071, <https://pubs.usgs.gov/of/2015/1071/pdf/ofr2015-1071.pdf>
- Vermeulen, T. (2011). Knowledge sharing report – CO₂ Liquid Logistics Shipping Concept (LLSC). Overall Supply Chain Optimization <http://www.globalccsinstitute.com/publications/knowledge-sharing-report-co2-liquid-logistics-shipping-concept-llsc-safety-health-and-environment-she-report>
- Vidas, H., B. Hugman, A. Chikkatur, B. Venkatesh. 2012. Analysis of the Costs and Benefits of CO₂ Sequestration on the U.S. Outer Continental Shelf. U.S. Department of the Interior, Bureau of Ocean Energy Management. Herndon, Virginia. OCS Study BOEM 2012- 100.
- Welkenhuysen, K., Meyvis, B. & Piessens, K., 2015. Techno-economic evaluation of CO₂-EOR in the North Sea. Scottish Carbon Capture and Storage (SCCS) CO₂-EOR Joint Industry Project, 41p.
- Welkenhuysen, K., B. Meyvis, K. Piessens, 2017. A profitability study of CO₂-EOR and subsequent CO₂ storage in the North Sea under low oil market prices. *Energy Procedia* 00 (2017) 000 - 000

White, D. 2013. Seismic characterization and time-lapse imaging during seven years of CO₂ flood in the Weyburn field, Saskatchewan, Canada. *International Journal of Greenhouse Gas Control*, 16, S78-S94.

Wolaver, B.D., Hovorka, S.D., Smyth, R.C., 2013. Greensites and brownsites: Implications for CO₂ sequestration characterization, risk assessment, and monitoring. *International Journal of Greenhouse Gas Control* 19, 49-62.

Yan, W., Miller, C.A. and Hirasaki, G.J., 2006. Foam sweep in fractures for enhanced oil recovery. *Colloids and Surfaces A: Physicochem. Eng. Aspects*

Yu, H. et al., 2008. Air Foam Injection for IOR: from Laboratory to Field Implementation in Zhongyuan Oilfield China. Society of Petroleum Engineers.

Yu, C., C. Huang, C. Tan, 2012. A review of CO₂ capture by absorption and adsorption. *Aerosol and Air Quality Research*, 12: 745-769

ZEP (2017). Future CCS technologies. January 2017.

<http://www.zeroemissionsplatform.eu/news/news/1665-zep-publishes-future-ccs-technologies-report.html>

Zuta, J. and Fjelde, I., 2010. Transport of CO₂-Foaming Agents During CO₂-Foam Processes in Fractured Chalk Rock.